



# CALCULATION PACKAGE

---

February 24, 2021

## Architectural Innovations

### Pratt Plat – Lot 2

Mercer Island,  
Washington

---

#### MULHERN & KULP STRUCTURAL ENGINEERING, INC.

Prepared By:

Riley J. Denis, E.I.T.

*Staff Engineer*

Nicholas J. Martignetti, P.E.

*Associate Owner + San Diego Office Director*

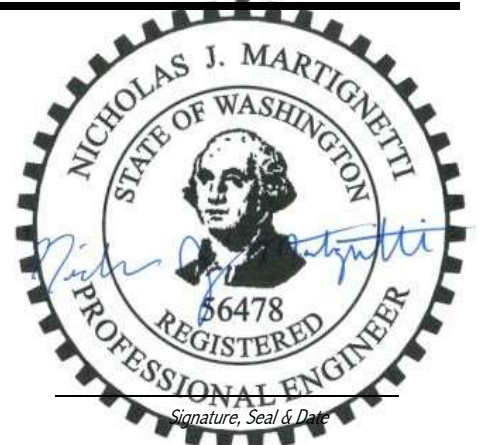

*Signature, Seal & Date*



**BEAM & HEADER CALCULATIONS**

BEAM DESCRIPTION: 4x10 HDR - WORST CASE LOAD

B1

PARAMETERS:

L =  FT  
W =  KLF  
P =  K

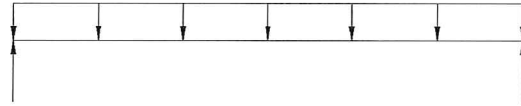

ANALYSIS:

$R_{MAX} =$  K       $V_D =$  K       $< V_{ALL} =$  K       ADEQUATE  
 $M_{MAX} =$  K-FT       $< M_{ALL} =$  K-FT       ADEQUATE  
 $\Delta_{TL} =$  IN.       $L/$   $< L/240$        ADEQUATE

BEAM DESCRIPTION: 4x10 HDR - WORST CASE LENGTH

B1

PARAMETERS:

L =  FT  
W =  KLF  
P =  K

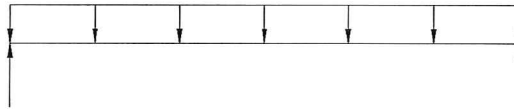

ANALYSIS:

$R_{MAX} =$  K       $V_D =$  K       $< V_{ALL} =$  K       ADEQUATE  
 $M_{MAX} =$  K-FT       $< M_{ALL} =$  K-FT       ADEQUATE  
 $\Delta_{TL} =$  IN.       $L/$   $< L/240$        ADEQUATE

BEAM DESCRIPTION: ROOF FRAMING - Dropped

BEAM @ OPEN TO BELOW

B2

PARAMETERS:

L =  FT  
W =  KLF  
P =  K

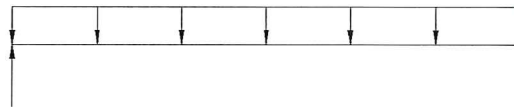

ANALYSIS:

$R_{MAX} =$  K       $V_D =$  K       $< V_{ALL} =$  K       ADEQUATE  
 $M_{MAX} =$  K-FT       $< M_{ALL} =$  K-FT       ADEQUATE  
 $\Delta_{TL} =$  IN.       $L/$   $< L/240$        ADEQUATE

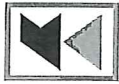

**BEAM & HEADER CALCULATIONS**

BEAM DESCRIPTION: ROOF FRAMING - HEADER @ REAR UTILITY WINDOW 133

PARAMETERS:

L =  FT  
W<sub>1</sub> =  KLF W<sub>2</sub> = 0.57  
P =  K

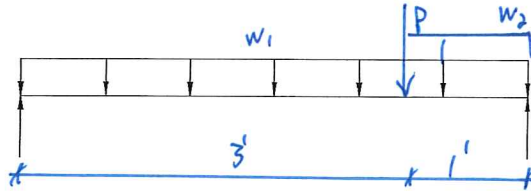

ANALYSIS:

R<sub>MAX</sub> =  K      V<sub>D</sub> =  K < V<sub>ALL</sub> =  K       ADEQUATE  
M<sub>MAX</sub> =  K-FT < M<sub>ALL</sub> =  K-FT       ADEQUATE  
Δ<sub>TL</sub> =  IN.      L/  < L/240       ADEQUATE

4x10

BEAM DESCRIPTION: UPPER FLOOR FRAMING - 9' GARAGE DOOR 134

PARAMETERS:

L =  FT  
W =  KLF  
P =  K

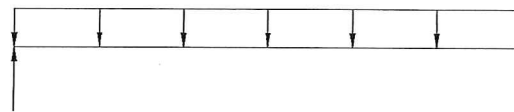

ANALYSIS:

R<sub>MAX</sub> =  K      V<sub>D</sub> =  K < V<sub>ALL</sub> =  K       ADEQUATE  
M<sub>MAX</sub> =  K-FT < M<sub>ALL</sub> =  K-FT       ADEQUATE  
Δ<sub>TL</sub> =  IN.      L/  < L/240       ADEQUATE

4x12

BEAM DESCRIPTION: UPPER FLOOR FRAMING - FLUSH BOTTOM BEAM @ FRONT OF GARAGE 135

PARAMETERS:

L =  FT  
W =  KLF  
P =  K

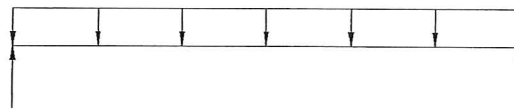

ANALYSIS:

R<sub>MAX</sub> =  K      V<sub>D</sub> =  K < V<sub>ALL</sub> =  K       ADEQUATE  
M<sub>MAX</sub> =  K-FT < M<sub>ALL</sub> =  K-FT       ADEQUATE  
Δ<sub>TL</sub> =  IN.      L/  < L/240       ADEQUATE

5 1/2 x 15" GLB

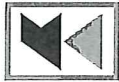

**BEAM & HEADER CALCULATIONS**

**BEAM DESCRIPTION:** UPPER FLOOR FRAMING - FLUSH BOT BEAM @ REAR OF GARAGE B36

PARAMETERS:

L =  FT  
W =  KLF  
P =  K

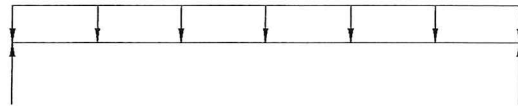

ANALYSIS:

$R_{MAX} =$  K       $V_D =$  K       $< V_{ALL} =$  K       ADEQUATE  
 $M_{MAX} =$  K-FT       $< M_{ALL} =$  K-FT       ADEQUATE  
 $\Delta_{TL} =$  IN.      L/  < L/240       ADEQUATE

5 1/2" x 15" GLB

**BEAM DESCRIPTION:** UPPER FLOOR FRAMING - FRONT TO BACK BEAM @ GARAGE B37

PARAMETERS:

L =  FT  
W =  KLF  
P =  K

(SEE ENERCALL OUTPUT FOR OVERSTRENGTH CALC)

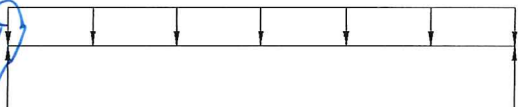

ANALYSIS:

$R_{MAX} =$  K       $V_D =$  K       $< V_{ALL} =$  K       ADEQUATE  
 $M_{MAX} =$  K-FT       $< M_{ALL} =$  K-FT       ADEQUATE  
 $\Delta_{TL} =$  IN.      L/  < L/240       ADEQUATE

7" x 18" LVL

**BEAM DESCRIPTION:** UPPER FLOOR FRAMING - 17' GARAGE DOOR HEADER B38

PARAMETERS:

L =  FT  
W =  KLF  
P =  K

(SEE ENERCALL OUTPUT FOR OVERSTRENGTH CALC)

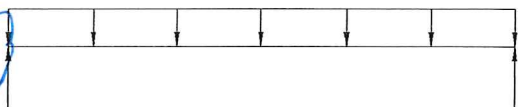

ANALYSIS:

$R_{MAX} =$  K       $V_D =$  K       $< V_{ALL} =$  K       ADEQUATE  
 $M_{MAX} =$  K-FT       $< M_{ALL} =$  K-FT       ADEQUATE  
 $\Delta_{TL} =$  IN.      L/  < L/240       ADEQUATE

5 1/2" x 15" GLB



**BEAM & HEADER CALCULATIONS**

**BEAM DESCRIPTION:** UPPER FLOOR FRAMING - FLUSH BOTTOM BEAM @ PANTRY

B9

PARAMETERS:

L = 9 FT

W = 0.92 KLF

P = - K

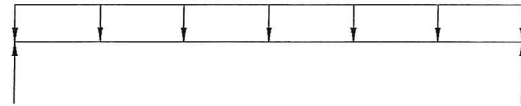

ANALYSIS:

R<sub>MAX</sub> = 4.14 K      V<sub>D</sub> = [ ] K < V<sub>ALL</sub> = 7.42 K       ADEQUATE

M<sub>MAX</sub> = 9.32 K-FT < M<sub>ALL</sub> = 16.8 K-FT       ADEQUATE

Δ<sub>TL</sub> = 0.15 IN.      L/720 < L/240       ADEQUATE

3 1/2" X 12" GLB

**BEAM DESCRIPTION:** UPPER FLOOR FRAMING - FLUSH BEAM @ KITCHEN

B10

PARAMETERS:

L = 17 FT

W = 0.167 KLF

P = 4.14 K

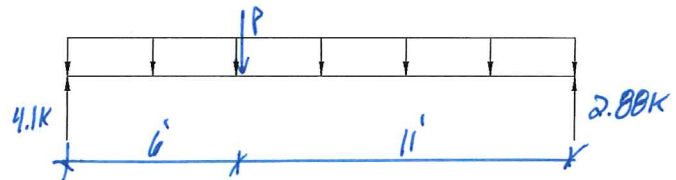

ANALYSIS:

R<sub>MAX</sub> = 4.1 K      V<sub>D</sub> = [ ] K < V<sub>ALL</sub> = 11.13 K       ADEQUATE

M<sub>MAX</sub> = 21.6 K-FT < M<sub>ALL</sub> = 37.8 K-FT       ADEQUATE

Δ<sub>TL</sub> = 0.37 IN.      L/550 < L/240       ADEQUATE

3 1/2" X 18" GLB

**BEAM DESCRIPTION:** UPPER FLOOR FRAMING - HEADERS @ REAR OF KITCHEN (WORST CASE)

B11

PARAMETERS:

L = 7 FT

W = 1.14 KLF

P = - K

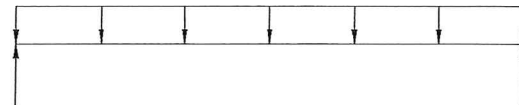

ANALYSIS:

R<sub>MAX</sub> = 3.99 K      V<sub>D</sub> = [ ] K < V<sub>ALL</sub> = 5.56 K       ADEQUATE

M<sub>MAX</sub> = 6.98 K-FT < M<sub>ALL</sub> = 9.45 K-FT       ADEQUATE

Δ<sub>TL</sub> = 0.16 IN.      L/525 < L/240       ADEQUATE

3 1/2" X 9" GLB

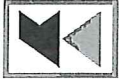

**BEAM & HEADER CALCULATIONS**

**BEAM DESCRIPTION:** UPPER FLOOR FRAMING - FLUSH BOTTOM BEAM @ FOYER 1B12

PARAMETERS:

L = 15.5 FT

W = 0.57 KLF

P = - K

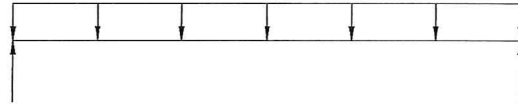

ANALYSIS:

R<sub>MAX</sub> = 4.41 K      V<sub>D</sub> = [ ] K < V<sub>ALL</sub> = 11.13 K       ADEQUATE

M<sub>MAX</sub> = 17.12 K-FT < M<sub>ALL</sub> = 37.8 K-FT       ADEQUATE

Δ<sub>TL</sub> = 0.24 IN.      L/775 < L/240       ADEQUATE

3 1/2"x18" GLB

**BEAM DESCRIPTION:** UPPER FLOOR FRAMING - DROPPED BEAM @ FRONT PORCH 1B13

PARAMETERS:

L = 16 FT

W = 0.2 KLF

P = - K

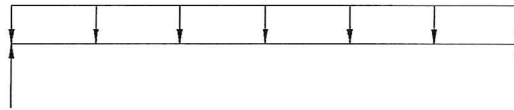

ANALYSIS:

R<sub>MAX</sub> = 1.6 K      V<sub>D</sub> = [ ] K < V<sub>ALL</sub> = 7.168 K       ADEQUATE

M<sub>MAX</sub> = 6.4 K-FT < M<sub>ALL</sub> = 8.84 K-FT       ADEQUATE

Δ<sub>TL</sub> = 0.33 IN.      L/581 < L/240       ADEQUATE

6x12

**BEAM DESCRIPTION:** UPPER FLOOR FRAMING - GREAT ROOM FRONT WINDOW HDR 1B14

PARAMETERS:

L = 8 FT

W = 0.69 KLF

P = - K

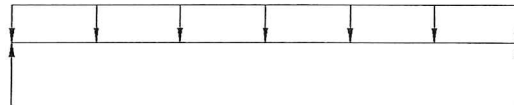

ANALYSIS:

R<sub>MAX</sub> = 2.76 K      V<sub>D</sub> = [ ] K < V<sub>ALL</sub> = 5.922 K       ADEQUATE

M<sub>MAX</sub> = 5.52 K-FT < M<sub>ALL</sub> = 6.032 K-FT       ADEQUATE

Δ<sub>TL</sub> = 0.125 IN.      L/770 < L/240       ADEQUATE

6x10

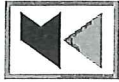

**BEAM & HEADER CALCULATIONS**

BEAM DESCRIPTION: UPPER FLOOR FRAMING- GREAT ROOM SGD HDR B15

PARAMETERS:

L =  FT  
W =  KLF  
P =  K

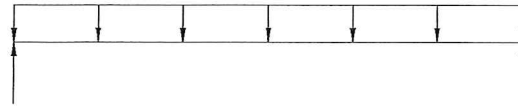

ANALYSIS:

$R_{MAX} =$  K  $V_D =$  K  $< V_{ALL} =$  K  ADEQUATE  
 $M_{MAX} =$  K-FT  $< M_{ALL} =$  K-FT  ADEQUATE  
 $\Delta_{TL} =$  IN.  $L/$   $< L/240$   ADEQUATE

5 1/2" X 13 1/2" GLB

BEAM DESCRIPTION: UPPER FLOOR FRAMING- FLUSH BEAM @ SIDE OF REAR PORCH B16

PARAMETERS:

L =  FT  
W =  KLF  
P =  K

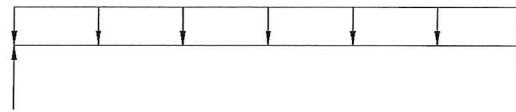

ANALYSIS:

$R_{MAX} =$  K  $V_D =$  K  $< V_{ALL} =$  K  ADEQUATE  
 $M_{MAX} =$  K-FT  $< M_{ALL} =$  K-FT  ADEQUATE  
 $\Delta_{TL} =$  IN.  $L/$   $< L/240$   ADEQUATE

3 1/2" X 18" GLB

BEAM DESCRIPTION: UPPER FLOOR FRAMING- FLUSH BEAM @ REAR OF REAR PORCH B17

PARAMETERS:

L =  FT  
W =  KLF  
P =  K

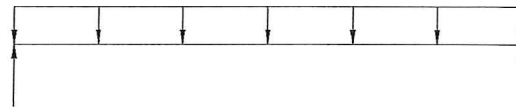

ANALYSIS:

$R_{MAX} =$  K  $V_D =$  K  $< V_{ALL} =$  K  ADEQUATE  
 $M_{MAX} =$  K-FT  $< M_{ALL} =$  K-FT  ADEQUATE  
 $\Delta_{TL} =$  IN.  $L/$   $< L/240$   ADEQUATE

3 1/2" X 18" GLB

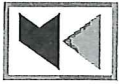

**BEAM & HEADER CALCULATIONS**

BEAM DESCRIPTION: MAIN FLOOR FRAMING - Dropped BEAM @ REAR OF CRAWL B19

PARAMETERS:

L =  FT  
W =  KLF  
P =  K

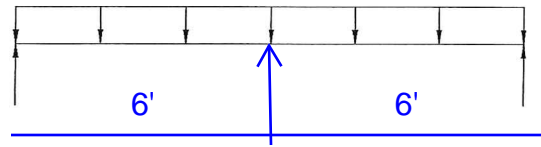

ANALYSIS:

$R_{MAX} =$  K      $V_D =$  K <  $V_{ALL} =$  K      ADEQUATE  
 $M_{MAX} =$  K-FT <  $M_{ALL} =$  K-FT      ADEQUATE  
 $\Delta_{TL} =$  IN.      $L/$  <  $L/240$       ADEQUATE

6x10 dropped

BEAM DESCRIPTION: MAIN FLOOR FRAMING - Dropped BEAM @ FRONT OF CRAWL B19

PARAMETERS:

L =  FT  
W =  KLF  
P =  K

SEE ENER CALC  
OUTPUT FOR  
OVERSTRENGTH  
CALCS

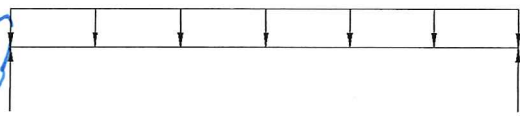

ANALYSIS:

$R_{MAX} =$  K      $V_D =$  K <  $V_{ALL} =$  K      ADEQUATE  
 $M_{MAX} =$  K-FT <  $M_{ALL} =$  K-FT      ADEQUATE  
 $\Delta_{TL} =$  IN.      $L/$  <  $L/240$       ADEQUATE

6x10 dropped

BEAM DESCRIPTION: MAIN FLOOR FRAMING - FLUSH BOTTOM BEAM @ MECH B20

PARAMETERS:

L =  FT  
W =  KLF      $w_2 = 0.77$   
P =  K

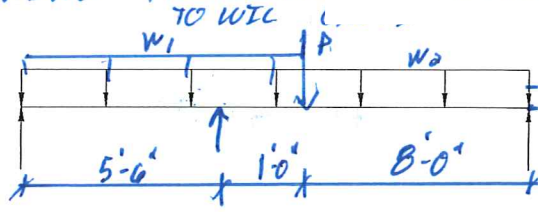

ANALYSIS:

$R_{MAX} =$  K      $V_D =$  K <  $V_{ALL} =$  K      ADEQUATE  
 $M_{MAX} =$  K-FT <  $M_{ALL} =$  K-FT      ADEQUATE  
 $\Delta_{TL} =$  IN.      $L/$  <  $L/240$       ADEQUATE

3 1/2" x 12" GLB



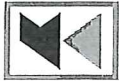

**BEAM & HEADER CALCULATIONS**

VOID

1302

BEAM DESCRIPTION: MAIN FLOOR FRAMING - FLUSH BEAM @ BEDS W/ DECK ADV. 1302

PARAMETERS:

L = 11 FT  
W = 0.74 KLF  
P = - K

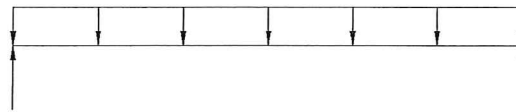

ANALYSIS:

$R_{MAX} = 4.07$  K       $V_D =$  [ ] K       $< V_{ALL} = 11.13$  K       ADEQUATE  
 $M_{MAX} = 11.19$  K-FT       $< M_{ALL} = 378$  K-FT       ADEQUATE  
 $\Delta_{TL} = 0.08$  IN.       $L/9994 < L/240$        ADEQUATE

3 1/2" x 10" GLB

VOID

1303



**BEAM & HEADER CALCULATIONS**

BEAM DESCRIPTION: MAIN FLOOR FRAMING - FLUSH BOT HOR @ BED 6

B24

PARAMETERS:

L =  FT  
W =  KLF  
P =  K

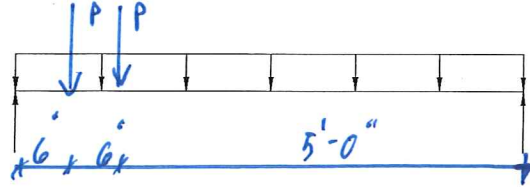

ANALYSIS:

$R_{MAX} =$  K       $V_D =$  K       $< V_{ALL} =$  K       ADEQUATE  
 $M_{MAX} =$  K-FT       $< M_{ALL} =$  K-FT       ADEQUATE  
 $\Delta_{TL} =$  IN.       $L/$   $< L/240$        ADEQUATE

BEAM DESCRIPTION:

PARAMETERS:

L =  FT  
W =  KLF  
P =  K

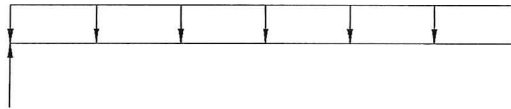

ANALYSIS:

$R_{MAX} =$  K       $V_D =$  K       $< V_{ALL} =$  K       ADEQUATE  
 $M_{MAX} =$  K-FT       $< M_{ALL} =$  K-FT       ADEQUATE  
 $\Delta_{TL} =$  IN.       $L/$   $< L/240$        ADEQUATE

BEAM DESCRIPTION:

PARAMETERS:

L =  FT  
W =  KLF  
P =  K

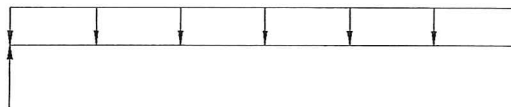

ANALYSIS:

$R_{MAX} =$  K       $V_D =$  K       $< V_{ALL} =$  K       ADEQUATE  
 $M_{MAX} =$  K-FT       $< M_{ALL} =$  K-FT       ADEQUATE  
 $\Delta_{TL} =$  IN.       $L/$   $< L/240$        ADEQUATE

**OVERSTRENGTH CALCULATIONS**

**WALL DESCRIPTION/SW #:**

201

**PARAMETERS:**

L = 7.0 FT  
H = 9.0 FT  
E = 0.70 K  
W<sub>DLWALL</sub> = 0.10 KLF  
W<sub>DL</sub> = 0.034 KLF  
Ω<sub>0</sub> = 2.5 (ASCE TABLE 12.2.1 FOOTNOTE G)  
SDS = 0.976

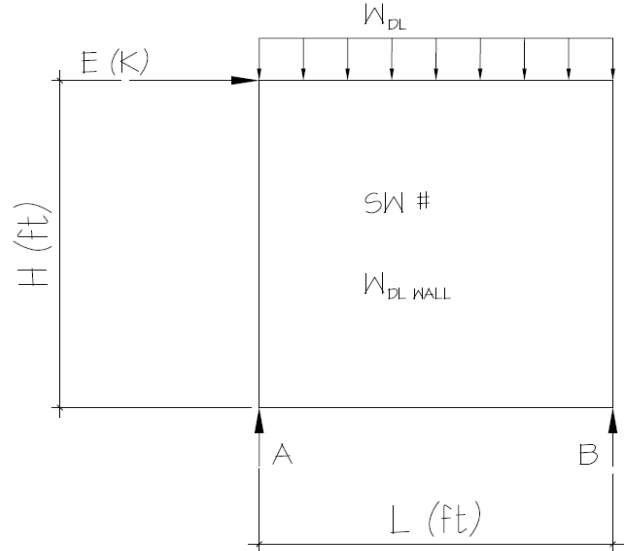

**ANALYSIS:**

$E_{MH} = \Omega_0 * E = 1.75$  K       $E_v = 0.2 * SDS * DL = 0.183$  K  
 $E_M = E_{MH} + E_v = 1.933$  K  
 $E_M = E_{MH} - E_v = 1.567$  K

$E_M (MAX) = \sum M_A = 0 = 1.93(9.0) + 0.134(7)(3.5) - R_B(7)$        $R_B = 0.5DL + 2.5E$   
 $R_A = 0.5DL - 2.5E$   
 $E_M (MIN) = \sum M_A = 0 = 1.57(9.0) + 0.134(7)(3.5) - R_B(7)$        $R_B = 0.5DL + 2.0E$   
 $R_A = 0.5DL - 2.0E$

CHECK BEAMS FOR AXIAL FORCES SHOWN USING LOAD COMBOS PER SECTION 12.4.3.1 (ASD)

ALLOWABLE STRESS PERMITTED TO BE INCREASED BY 1.2

SEE FOLLOWING BEAM  
CALCS FOR LOAD  
APPLICATION

**OVERSTRENGTH CALCULATIONS**

**WALL DESCRIPTION/SW #:**

205

**PARAMETERS:**

L = 13.5 FT  
 H = 9.0 FT  
 E = 1.55 K  
 W<sub>DL WALL</sub> = 0.10 KLF  
 W<sub>DL</sub> = 0.000 KLF  
 Ω<sub>0</sub> = 2.5 (ASCE TABLE 12.2.1 FOOTNOTE G)  
 SDS = 0.976

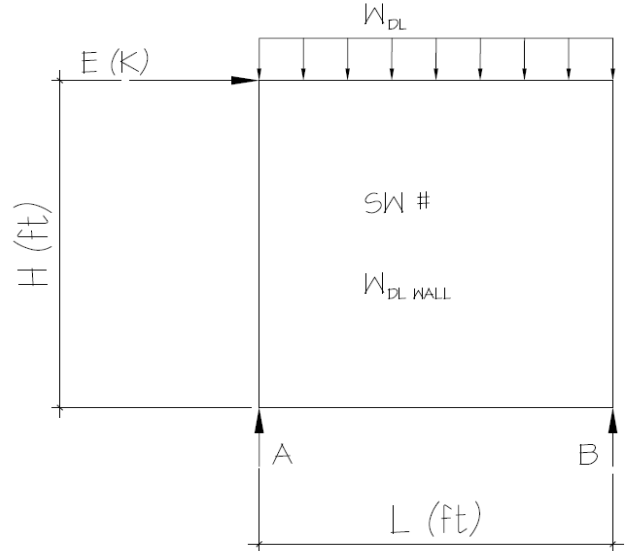

**ANALYSIS:**

$E_{MH} = \Omega_0 * E = 3.88$  K       $E_v = 0.2 * SDS * DL = 0.264$  K  
 $E_M = E_{MH} + E_v = 4.139$  K  
 $E_M = E_{MH} - E_v = 3.611$  K

$E_M (MAX) = \sum M_A = 0 = 4.14(9.0) + 0.1(13.5)(6.75) - R_B(13.5)$        $R_B = 0.7DL + 2.8E$   
 $R_A = 0.7DL - 2.8E$

$E_M (MIN) = \sum M_A = 0 = 3.61(9.0) + 0.1(13.5)(6.75) - R_B(13.5)$        $R_B = 0.7DL + 2.4E$   
 $R_A = 0.7DL - 2.4E$

CHECK BEAMS FOR AXIAL FORCES SHOWN USING LOAD COMBOS PER SECTION 12.4.3.1 (ASD)

ALLOWABLE STRESS PERMITTED TO BE INCREASED BY 1.2

SEE FOLLOWING BEAM  
CALCS FOR LOAD  
APPLICATION

**OVERSTRENGTH CALCULATIONS**

**WALL DESCRIPTION/SW #:**

104

**PARAMETERS:**

- L = 13.5 FT
- H = 10.0 FT
- E = 1.65 K
- $W_{DLWALL}$  = 0.20 KLF
- $W_{DL}$  = 0.000 KLF
- $\Omega_0$  = 2.5 (ASCE TABLE 12.2.1 FOOTNOTE G)
- SDS = 0.976

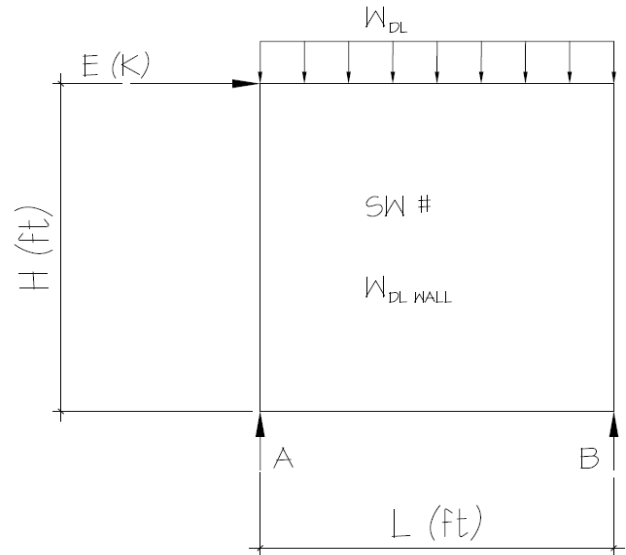

**ANALYSIS:**

$$E_{MH} = \Omega_0 * E = 4.13 \text{ K}$$

$$E_v = 0.2 * SDS * DL = 0.527 \text{ K}$$

$$E_M = E_{MH} + E_v = 4.652 \text{ K}$$

$$E_M = E_{MH} - E_v = 3.598 \text{ K}$$

$$E_M \text{ (MAX)} = \sum M_A = 0 = 4.65(10.0) + 0.2(13.5)(6.75) - R_B(13.5)$$

$$R_B = 1.4DL + 3.4E$$

$$R_A = 1.4DL - 3.4E$$

$$E_M \text{ (MIN)} = \sum M_A = 0 = 3.60(10.0) + 0.2(13.5)(6.75) - R_B(13.5)$$

$$R_B = 1.4DL + 2.7E$$

$$R_A = 1.4DL - 2.7E$$

CHECK BEAMS FOR AXIAL FORCES SHOWN USING LOAD COMBOS PER SECTION 12.4.3.1 (ASD)

ALLOWABLE STRESS PERMITTED TO BE INCREASED BY 1.2

SEE FOLLOWING BEAM  
CALCS FOR LOAD  
APPLICATION

## Wood Beam

Lic. # : KW-06004787

DESCRIPTION: B7 - Front to back Garage Beam

### CODE REFERENCES

Calculations per NDS 2018, IBC 2018, CBC 2019, ASCE 7-16  
Load Combination Set : ASCE 7-16

### Material Properties

Analysis Method : Allowable Stress Design	Fb +	3,120.0 psi	E : Modulus of Elasticity
Load Combination : ASCE 7-16	Fb -	3,120.0 psi	Ebend- xx
	Fc - Prll	3,012.0 psi	Eminbend - xx
Wood Species : Trus Joist	Fc - Perp	900.0 psi	
Wood Grade : MicroLam LVL 2.0 E	Fv	342.0 psi	
	Ft	1,866.0 psi	Density
Beam Bracing : Beam is Fully Braced against lateral-torsional buckling			42.010pcf

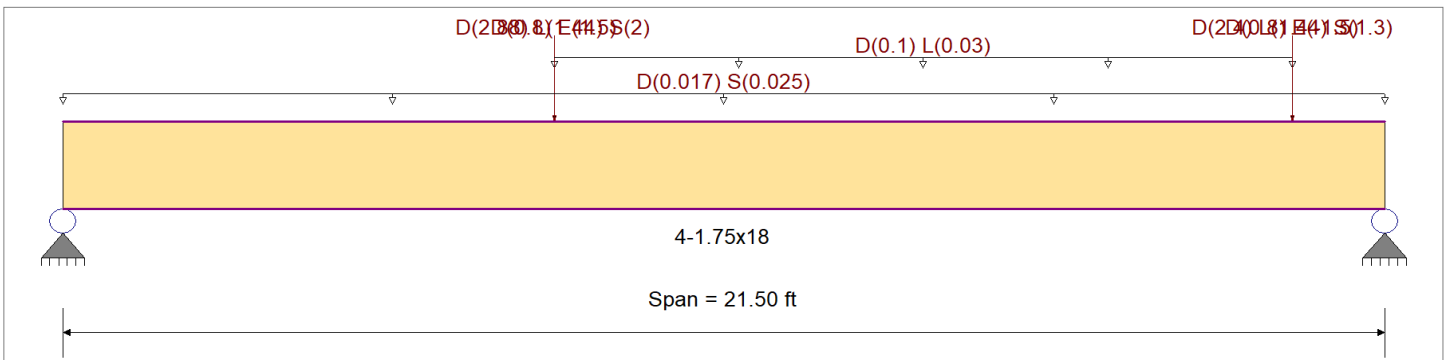

### Applied Loads

Service loads entered. Load Factors will be applied for calculations.

Beam self weight calculated and added to loads

- Uniform Load : D = 0.0170, S = 0.0250, Tributary Width = 1.0 ft
- Uniform Load : D = 0.10, L = 0.030 k/ft, Extent = 8.0 --> 20.0 ft, Tributary Width = 1.0 ft
- Point Load : D = 2.40, L = 1.440, S = 1.30 k @ 20.0 ft
- Point Load : D = 2.880, L = 1.440, S = 2.0 k @ 8.0 ft
- Point Load : D = 0.80, E = 1.50 k @ 8.0 ft
- Point Load : D = 0.80, E = -1.50 k @ 20.0 ft

### DESIGN SUMMARY

Design OK

Maximum Bending Stress Ratio	=	<b>0.396</b>	1	Maximum Shear Stress Ratio	=	<b>0.269</b>	: 1
Section used for this span		<b>4-1.75x18</b>		Section used for this span		<b>4-1.75x18</b>	
fb: Actual	=	1,345.77 psi		fv: Actual	=	92.08 psi	
Fb: Allowable	=	3,395.50 psi		Fv: Allowable	=	342.00 psi	
Load Combination		+D+0.750L+0.750S+H		Load Combination		+D+L+H	
Location of maximum on span	=	8.004 ft		Location of maximum on span	=	20.009 ft	
Span # where maximum occurs	=	Span # 1		Span # where maximum occurs	=	Span # 1	
<b>Maximum Deflection</b>							
Max Downward Transient Deflection		0.129 in	Ratio =	2005	>=	360	
Max Upward Transient Deflection		0.000 in	Ratio =	0	<	360	
Max Downward Total Deflection		0.500 in	Ratio =	515	>=	300	
Max Upward Total Deflection		0.000 in	Ratio =	0	<	300	

### Overall Maximum Deflections

Load Combination	Span	Max. "-" Defl	Location in Span	Load Combination	Max. "+" Defl	Location in Span
+D+0.750L+0.750S+0.5250E+H	1	0.5004	10.436		0.0000	0.000

### Vertical Reactions

Support notation : Far left is #1

Values in KIPS

Load Combination	Support 1	Support 2
Overall MAXimum	6.029	8.954
Overall MINimum	0.837	-0.837
+D+H	3.530	5.705
+D+L+H	4.661	7.815
+D+Lr+H	3.530	5.705

Pratt Plat  
Arch Innovations  
203-20001  
RJD  
02-22-21

## Wood Beam

File: beam calcs with overstrength.ec6  
Software copyright ENERCALC, INC. 1983-2020, Build:12.20.8.17  
MULHERN & KULP STRUCTURAL ENGINEERING INC

Lic. # : KW-06004787

DESCRIPTION: B7 - Front to back Garage Beam

Load Combination	Support notation : Far left is #1		Values in KIPS
	Support 1	Support 2	
+D+S+H	5.146	7.928	
+D+0.750Lr+0.750L+H	4.378	7.288	
+D+0.750L+0.750S+H	5.590	8.954	
+D+0.60W+H	3.530	5.705	
+D+0.750Lr+0.750L+0.450W+H	4.378	7.288	
+D+0.750L+0.750S+0.450W+H	5.590	8.954	
+0.60D+0.60W+0.60H	2.118	3.423	
+D+0.70E+0.60H	4.117	5.119	
+D+0.750L+0.750S+0.5250E+H	6.029	8.515	
+0.60D+0.70E+H	2.704	2.837	
D Only	3.530	5.705	
L Only	1.130	2.110	
S Only	1.615	2.222	
E Only	0.837	-0.837	
H Only			

## Wood Beam

Lic. #: KW-06004787

File: beam calcs with overstrength.ec6  
Software copyright ENERCALC, INC. 1983-2020, Build:12.20.8.17  
MULHERN & KULP STRUCTURAL ENGINEERING INC

DESCRIPTION: B8 - 17' Garage Door Header

### CODE REFERENCES

Calculations per NDS 2018, IBC 2018, CBC 2019, ASCE 7-16  
Load Combination Set : ASCE 7-16

### Material Properties

Analysis Method : Allowable Stress Design  
Load Combination : ASCE 7-16

Wood Species : DF/DF  
Wood Grade : 24F-V4

Beam Bracing : Beam is Fully Braced against lateral-torsional buckling

Fb + 2,400.0 psi  
Fb - 1,850.0 psi  
Fc - Prll 1,650.0 psi  
Fc - Perp 650.0 psi  
Fv 265.0 psi  
Ft 1,100.0 psi  
E : Modulus of Elasticity  
Ebend- xx 1,800.0ksi  
Eminbend - xx 950.0ksi  
Ebend- yy 1,600.0ksi  
Eminbend - yy 850.0ksi  
Density 31.210pcf

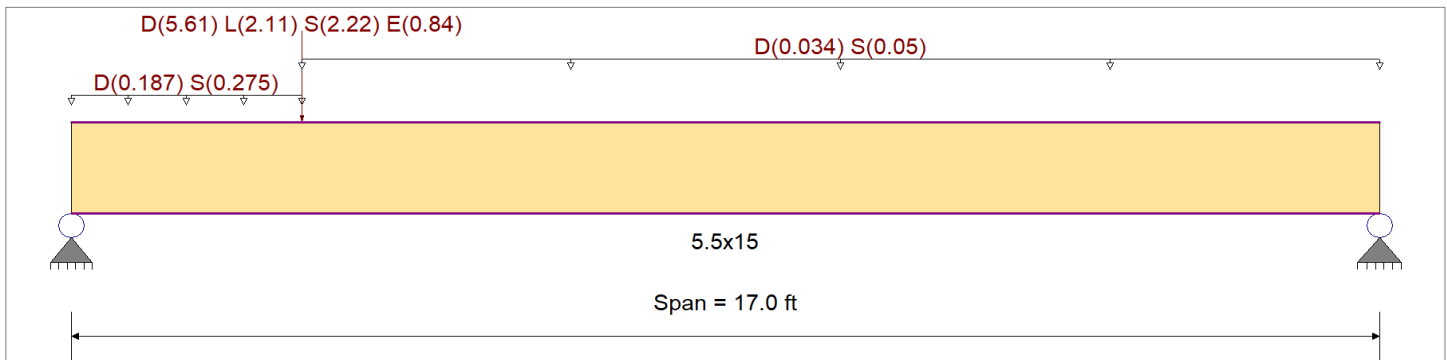

### Applied Loads

Service loads entered. Load Factors will be applied for calculations.

Beam self weight calculated and added to loads  
Load for Span Number 1

Uniform Load : D = 0.1870, S = 0.2750 k/ft, Extent = 0.0 --> 3.0 ft, Tributary Width = 1.0 ft  
Point Load : D = 5.610, L = 2.110, S = 2.220, E = 0.840 k @ 3.0 ft  
Uniform Load : D = 0.0340, S = 0.050 k/ft, Extent = 3.0 --> 17.0 ft, Tributary Width = 1.0 ft

### DESIGN SUMMARY

**Design OK**

Maximum Bending Stress Ratio	=	<b>0.529</b>	1	Maximum Shear Stress Ratio	=	<b>0.503</b>	1
Section used for this span		<b>5.5x15</b>		Section used for this span		<b>5.5x15</b>	
fb: Actual	=	1,449.08	psi	fv: Actual	=	153.16	psi
Fb: Allowable	=	2,737.34	psi	Fv: Allowable	=	304.75	psi
Load Combination		+D+0.750L+0.750S+H		Load Combination		+D+0.750L+0.750S+H	
Location of maximum on span	=	3.040	ft	Location of maximum on span	=	0.000	ft
Span # where maximum occurs	=	Span # 1		Span # where maximum occurs	=	Span # 1	
<b>Maximum Deflection</b>							
Max Downward Transient Deflection		0.118	in	Ratio =		1721	>=360
Max Upward Transient Deflection		0.000	in	Ratio =		0	<360
Max Downward Total Deflection		0.384	in	Ratio =		530	>=300
Max Upward Total Deflection		0.000	in	Ratio =		0	<300

### Overall Maximum Deflections

Load Combination	Span	Max. "-" Defl	Location in Span	Load Combination	Max. "+" Defl	Location in Span
+D+0.750L+0.750S+0.5250E+H	1	0.3843	7.569		0.0000	0.000

### Vertical Reactions

Support notation : Far left is #1

Values in KIPS

Load Combination	Support 1	Support 2
Overall MAXimum	9.297	2.486
Overall MINimum	0.692	0.148
+D+H	5.479	1.471
+D+L+H	7.217	1.844
+D+Lr+H	5.479	1.471
+D+S+H	8.348	2.348
+D+0.750Lr+0.750L+H	6.783	1.751



Pratt Plat  
Arch Innovations  
203-20001  
RJD  
02-22-21

## Wood Beam

File: beam calcs with overstrength.ec6  
Software copyright ENERCALC, INC. 1983-2020, Build:12.20.8.17  
MULHERN & KULP STRUCTURAL ENGINEERING INC

Lic. #: KW-06004787

DESCRIPTION: B8 - 17' Garage Door Header

### Vertical Reactions

Support notation : Far left is #1

Values in KIPS

Load Combination	Support 1	Support 2
+D+0.750L+0.750S+H	8.934	2.408
+D+0.60W+H	5.479	1.471
+D+0.750Lr+0.750L+0.450W+H	6.783	1.751
+D+0.750L+0.750S+0.450W+H	8.934	2.408
+0.60D+0.60W+0.60H	3.288	0.883
+D+0.70E+0.60H	5.964	1.575
+D+0.750L+0.750S+0.5250E+H	9.297	2.486
+0.60D+0.70E+H	3.772	0.987
D Only	5.479	1.471
L Only	1.738	0.372
S Only	2.869	0.876
E Only	0.692	0.148
H Only		

## Wood Beam

Lic. # : KW-06004787

File: beam calcs with overstrength.ec6  
Software copyright ENERCALC, INC. 1983-2020, Build:12.20.8.17  
MULHERN & KULP STRUCTURAL ENGINEERING INC

DESCRIPTION: B19 -Flush Bottom Beam @ Crawl

### CODE REFERENCES

Calculations per NDS 2018, IBC 2018, CBC 2019, ASCE 7-16  
Load Combination Set : ASCE 7-16

### Material Properties

Analysis Method : Allowable Stress Design  
Load Combination : ASCE 7-16

Wood Species : Douglas Fir-Larch  
Wood Grade : No.2

Beam Bracing : Beam is Fully Braced against lateral-torsional buckling

Fb +	900.0 psi	E : Modulus of Elasticity	
Fb -	900.0 psi	Ebend- xx	1,600.0ksi
Fc - Prll	1,350.0 psi	Eminbend - xx	580.0ksi
Fc - Perp	625.0 psi		
Fv	180.0 psi	Density	31.210pcf
Ft	575.0 psi		

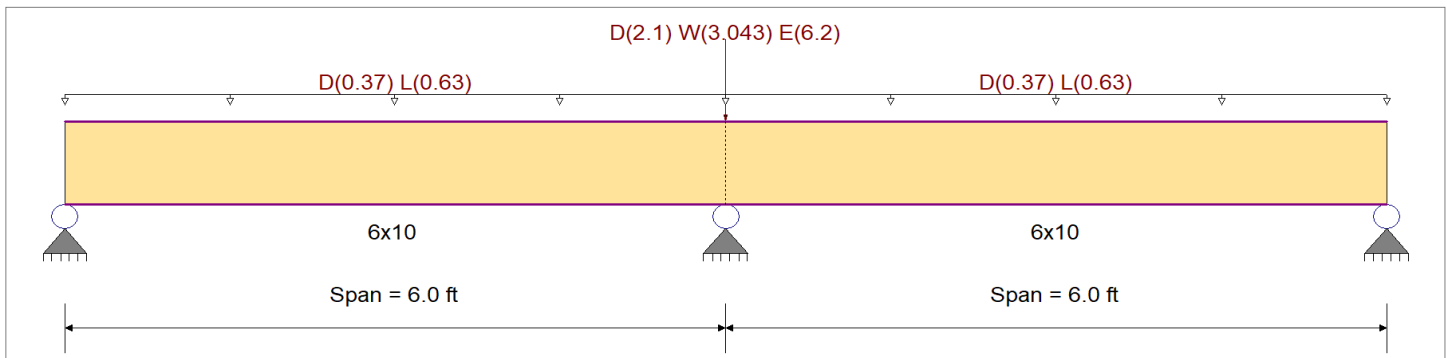

### Applied Loads

Service loads entered. Load Factors will be applied for calculations.

Beam self weight calculated and added to loads

Load for Span Number 1

Uniform Load : D = 0.370, L = 0.630, Tributary Width = 1.0 ft

Point Load : D = 2.10, W = 3.043, E = 6.20 k @ 6.0 ft

Load for Span Number 2

Uniform Load : D = 0.370, L = 0.630, Tributary Width = 1.0 ft

### DESIGN SUMMARY

**Design OK**

Maximum Bending Stress Ratio	=	<b>0.733</b> : 1	Maximum Shear Stress Ratio	=	<b>0.481</b> : 1
Section used for this span		<b>6x10</b>	Section used for this span		<b>6x10</b>
fb: Actual	=	660.12psi	fv: Actual	=	86.49 psi
Fb: Allowable	=	900.0psi	Fv: Allowable	=	180.00 psi
Load Combination		+D+L+H, LL Comb Run (LL)	Load Combination		+D+L+H, LL Comb Run (LL)
Location of maximum on span	=	6.000ft	Location of maximum on span	=	5.229 ft
Span # where maximum occurs	=	Span # 1	Span # where maximum occurs	=	Span # 1
<b>Maximum Deflection</b>					
Max Downward Transient Deflection		0.021 in	Ratio =		<b>3473</b> >=360
Max Upward Transient Deflection		-0.009 in	Ratio =		<b>7887</b> >=360
Max Downward Total Deflection		0.028 in	Ratio =		<b>2563</b> >=300
Max Upward Total Deflection		-0.005 in	Ratio =		<b>15871</b> >=300

### Overall Maximum Deflections

Load Combination	Span	Max. "-" Defl	Location in Span	Load Combination	Max. "+" Defl	Location in Span
+D+L+H, LL Comb Run (L*)	1	0.0281	2.749		0.0000	0.000
+D+L+H, LL Comb Run (*L)	2	0.0279	3.285	L Only, LL Comb Run (L*)	-0.0003	0.034

### Vertical Reactions

Support notation : Far left is #1

Values in KIPS

Load Combination	Support 1	Support 2	Support 3
Overall MAXimum	2.512	11.759	2.512
Overall MINimum	0.000	6.200	0.000
+D+H	0.858	4.960	0.858
+D+L+H, LL Comb Run (*L)	0.622	7.322	2.512
+D+L+H, LL Comb Run (L*)	2.512	7.322	0.622

Pratt Plat  
 Arch Innovations  
 203-20001  
 RJD  
 02-22-21

**Wood Beam**

Lic. # : KW-06004787

File: beam calcs with overstrength.ec6  
 Software copyright ENERCALC, INC. 1983-2020, Build:12.20.8.17  
**MULHERN & KULP STRUCTURAL ENGINEERING INC**

DESCRIPTION: B19 -Flush Bottom Beam @ Crawl

Load Combination	Support notation : Far left is #1			Values in KIPS
	Support 1	Support 2	Support 3	
+D+L+H, LL Comb Run (LL)	2.275	9.685	2.275	
+D+Lr+H, LL Comb Run (*L)	0.858	4.960	0.858	
+D+Lr+H, LL Comb Run (L*)	0.858	4.960	0.858	
+D+Lr+H, LL Comb Run (LL)	0.858	4.960	0.858	
+D+S+H	0.858	4.960	0.858	
+D+0.750Lr+0.750L+H, LL Comb Run (*	0.681	6.732	2.098	
+D+0.750Lr+0.750L+H, LL Comb Run (L	2.098	6.732	0.681	
+D+0.750Lr+0.750L+H, LL Comb Run (L	1.921	8.504	1.921	
+D+0.750L+0.750S+H, LL Comb Run (*L	0.681	6.732	2.098	
+D+0.750L+0.750S+H, LL Comb Run (L*	2.098	6.732	0.681	
+D+0.750L+0.750S+H, LL Comb Run (LL	1.921	8.504	1.921	
+D+0.60W+H	0.858	6.786	0.858	
+D+0.750Lr+0.750L+0.450W+H, LL Comb	0.681	8.101	2.098	
+D+0.750Lr+0.750L+0.450W+H, LL Comb	2.098	8.101	0.681	
+D+0.750Lr+0.750L+0.450W+H, LL Comb	1.921	9.873	1.921	
+D+0.750L+0.750S+0.450W+H, LL Comb	0.681	8.101	2.098	
+D+0.750L+0.750S+0.450W+H, LL Comb	2.098	8.101	0.681	
+D+0.750L+0.750S+0.450W+H, LL Comb	1.921	9.873	1.921	
+0.60D+0.60W+0.60H	0.515	4.802	0.515	
+D+0.70E+0.60H	0.858	9.300	0.858	
+D+0.750L+0.750S+0.5250E+H, LL Comb	0.681	9.987	2.098	
+D+0.750L+0.750S+0.5250E+H, LL Comb	2.098	9.987	0.681	
+D+0.750L+0.750S+0.5250E+H, LL Comb	1.921	11.759	1.921	
+0.60D+0.70E+H	0.515	7.316	0.515	
D Only	0.858	4.960	0.858	
L Only, LL Comb Run (*L)	-0.236	2.362	1.654	
L Only, LL Comb Run (L*)	1.654	2.362	-0.236	
L Only, LL Comb Run (LL)	1.418	4.725	1.418	
W Only	0.000	3.043	0.000	
E Only	0.000	6.200	0.000	
H Only				

ARCH INNOVATIONS  
PRATT PLAT - LOT 2

MERCER ISLAND, WA

SHEAR WALL CALCULATIONS - WIND DESIGN

*REVIEWED BY: NJM*

*FEBRUARY 22, 2021*

*PARAMETERS:*

*SINGLE FAMILY HOME*

*DESIGN WIND SPEED: 100 MPH*

*WIND EXPOSURE CATEGORY: B*

*SEISMIC DESIGN CATEGORY: D*

*CODE & DESIGN STANDARD: 2018 IBC CH. 1609, ASCE 7-16 CH. 26-30*



**MULHERN+KULP**  
RESIDENTIAL STRUCTURAL ENGINEERING

**WIND DESIGN SUMMARY PER ASCE 7-16**

PARAMETERS:		ROOF GEOMETRY:		BUILDING GEOMETRY:	
WIND SPEED	100	TRANS. ROOF PITCH	8.0 : 12	LENGTH	82 FT
EXPOSURE CATEGORY	B	LONG. ROOF PITCH	8.0 : 12	WIDTH	43 FT
RISK CATEGORY	II	MEAN ROOF HEIGHT, H	25.00 FT	NUMBER OF STORIES	2
WIND DIRECTIONALITY FACTOR, $K_D$	0.85				
TOPOGRAPHIC FACTOR, $K_{ZT}$	1.60				
GUST FACTOR, G	0.85				
GROUND ELEV. ABOVE SEA LEVEL (FT)	312				
DESIGN TYPE	ASD 0.60				

<b>TRANSVERSE DIRECTION (PERPENDICULAR TO MAIN RIDGE LINE)</b>						
DIAPHRAGM LEVEL	FLOOR-TO-FLOOR HEIGHT	SURFACE	SECTION			sq ft
			A	O	B	
2	9 FT	Roof Surface	0	288	0	sq ft
		Wall surface	0	450	0	sq ft
1	10 FT	Roof Surface	0	120	0	sq ft
		Wall surface	0	788	0	sq ft
FND		Roof Surface	0	0	0	sq ft
		Wall surface	0	0	0	sq ft

TRIBUTARY DESIGN LOADS: (0.6W)				
	SECTION			kips
	A	O	B	
Story Shear	0.00	9.43	0.00	kips
Total Shear	0.00	9.43	0.00	kips
	9.43			kips
Story Shear	0.00	12.18	0.00	kips
Total Shear	0.00	21.60	0.00	kips
	21.60			kips
Story Shear	0.00	0.00	0.00	kips
Total Shear	0.00	21.60	0.00	kips
	21.60			kips

<b>LONGITUDINAL DIRECTION (PARALLEL TO MAIN RIDGE LINE)</b>						
DIAPHRAGM LEVEL	FLOOR-TO-FLOOR HEIGHT	SURFACE	SECTION			sq ft
			A	O	B	
2	9 FT	Roof Surface	0	268	0	sq ft
		Wall surface	0	240	0	sq ft
1	10 FT	Roof Surface	0	0	0	sq ft
		Wall surface	0	390	0	sq ft
FND		Roof Surface	0	0	0	sq ft
		Wall surface	0	0	0	sq ft

TRIBUTARY DESIGN LOADS: (0.6W)				
	SECTION			kips
	A	O	B	
Story Shear	0.00	5.96	0.00	kips
Total Shear	0.00	5.96	0.00	kips
	5.96			kips
Story Shear	0.00	4.60	0.00	kips
Total Shear	0.00	10.56	0.00	kips
	10.56			kips
Story Shear	0.00	0.00	0.00	kips
Total Shear	0.00	10.56	0.00	kips
	10.56			kips

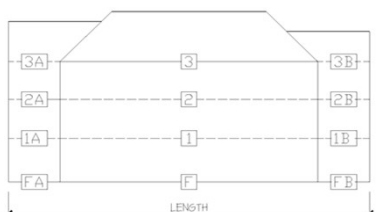
**GENERAL PLAN NOTES**

1. SEE SHEET A-1 FOR ALL GENERAL NOTES AND REQUIREMENTS.
2. ENERGY AND AIR QUALITY INFORMATION SEE DIV. II SHEET A-1
3. SEE BUILDING ELEVATION FOR WINDOW OPERATION SEE DIV. 8 SHEET A-1
4. SEE TYP. MATERIALS LIST ON SECTION SHEET
5. SEE SHEET A-1 FOR ALL NOTES AND REQUIREMENTS CONCERNING MECHANICAL, PLUMBING, AND ELECTRICAL.

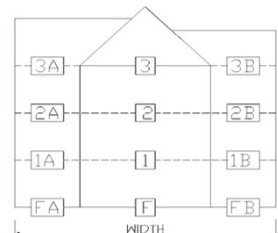
**FLOOR PLAN KEY NOTES**

- P-1 OCCUPANCY SEPARATION:  
APPLY (1) LAYER OF 1/2" GWB. TO GARAGE SIDE OF RESIDENCE, ATTIC SPACES, AND TO ALL BEAMS AND POSTS SUPPORTING A FLOOR-CEILING ASSEMBLY. APPLY (1) LAYER OF 1/2" TYPE "X" GWB. TO GARAGE CEILING UNDER HABITABLE ROOMS. DUCTS THROUGH WALL OR CEILING COMMON TO HOUSE SHALL HAVE MINIMUM 76 GAUGE STEEL. SEE DIV. 01007.6.A SHEET A-1
- P-2 1 1/2" MIN SELF CLOSING SOLID WOOD CORE, HONEY-COMB CORE STEEL, OR 20-MINUTE FIRE RATED DOOR. SEE DIV. 01007.6.B SHEET A-1
- P-3 STAIR ASSEMBLY NOTES: PER IRC, SECTION R301.5 AND DETAIL D107.  
A. HEADROOM MIN 6'-8", WIDTH MIN 3'-0".  
B. TREADS 10" MIN DEPTH AND MIN WIDTH OF 36" ABOVE HANDRAIL HEIGHT, RISERS 7 1/4" MAX HT. TREAD NOSING TO BE MINIMUM 3/4" AND A MAXIMUM OF 1/4" ON STAIRS WITH SOLID RISERS.  
C. HANDRAIL MIN 34" TO MAX 38" ABOVE TREAD NOSING. HANDRAIL TYPE I CIRCULAR TO HAVE 1 1/2" MIN TO 2" MAX CROSS SECTION DIMENSION AND 1/2" MIN CLEAR FROM WALL, RETURN RAIL ENDS. HANDRAILS SHALL BE STRONG ENOUGH TO RESIST A 200 LBS POINT LOAD IN ANY DIRECTION PER IRC, TABLE R301.5 D. INSTALL FIRE BLOCKING BETWEEN STRINGERS AT THE TOP AND BOTTOM OF EACH RUN PER IRC, SECTION R302.1  
E. COVER USABLE SPACE UNDER STAIR W 1/2" GWB. PER IRC, SECTION R302.1  
F. INTERMEDIATE BALUSTERS SHALL BE SPACED W LESS THAN 4" BETWEEN BALUSTERS.  
G. PROVIDE STAIRWAY ILLUMINATION PER IRC, SECTION R303.6. SEE DIV. 01007.1 SHEET A-1
- P-4 SAFETY GLAZING PER IRC, SECTION R308  
A. WINDOWS WITHIN 18" OF FLOOR  
B. WINDOWS WITHIN 24" ARC OF DOORS  
C. WINDOWS AT TUBS AND SHOWERS  
D. GLAZING IN DOORS  
E. LESS THAN 60" HORIZ FROM THE BOT. STAIR TREAD NOSING, 1 BOT. EDGE OF GLAZING IS LESS THAN 36" ABV. LANDING WALKING SURFACE. SEE DIV. 01007.1 SHEET A-1
- P-5 EGRESS WINDOW PER IRC, SECTION R310 SEE DIV. 01007.1 SHEET A-1
- P-6 IGNITERS FOR GAS FIRED APPLIANCES IN GARAGE TO BE 18" MIN. ABOVE TOP OF SLAB. SEE DIV. 15 SHEET A-1
- P-7 COVER WALLS ADJACENT TO TUBS AND SHOWERS WITH NON-ABSORBENT MATERIAL TO 7' ABOVE DRAIN INLETS, PER IRC, SECTION 3012. SEE DIV. 01015.0 SHEET A-1
- P-8 (2) LAYERS OF FLOOR SHEATHING OVER FRAMING.
- P-9 7/4" MAX RISER WITH 10" MIN RUN, IF MORE THAN (3) RISERS, HANDRAIL REQUIRED PER IRC, SECTION R301.5. SEE DIV. 01007.1 SHEET A-1
- P-10 18"x24" CRAWL SPACE ACCESS, INSULATE AND WEATHER STRIP. SEE DIV. 01007.1 SHEET A-1
- P-11 22"x36" ATTIC SPACE ACCESS W 30" HEAD CLEARANCE, INSULATE AND WEATHER STRIP. SEE DIV. 01007.2 SHEET A-1
- P-12 FLOOR MATERIAL BREAK LINE
- P-13 WALL LINE ABOVE
- P-14 WALL LINE BELOW
- P-15 FIREPLACE ASSEMBLY NOTES:  
A. DIRECT VENT GAS FIREPLACES, MUST BE LISTED, LABELED INSTALLED PER PFG. SPECIFICATIONS, SHALL CONFORM TO IRC REQUIREMENTS. SEE DIV. 01007.2 SHEET A-1  
B. ZERO CLEARANCE FIREPLACES SHALL CONFORM TO IRC REQUIREMENTS. SEE DIV. 01007.2 SHEET A-1  
C. HEARTH SHALL CONFORM TO IRC REQUIREMENT SEE DIV. 01007.2  
D. FIREBLOCK OPENINGS AROUND PENETRATIONS = EACH FLOOR PER IRC, SECTION R303.3.  
E. FIREPLACE MUST COMPLY WITH UL 117 TESTING
- P-16 SEE SITE PLAN FOR EXTENT OF WALKS & DRIVEWAYS
- P-17 3" DIAMETER STEEL POST
- P-18 36" GUARDRAIL PER IRC, SECTION R301 & TABLE R301.5 CONTRACTOR TO VERIFY TO INSPECTOR THAT ALL GUARDS & RAILINGS ARE CAPABLE OF RESISTING 200 LBS LOAD ON TOP RAIL ACTING IN ANY DIRECTION
- P-19 1" VENT FOR MECHANICAL, 1" CLEARANCE ALL SIDES PER IRC, SECTION R302.1 SEE DIV. 15 SHEET A-1
- P-20 PLANT SHELF
- P-21 UPPER AND LOWER LINEN CABINETS
- P-22 SOFFIT AREA
- P-23 INTEGRATED MAKE UP AIR
- P-24 2x6 STUDS W R-21 INSULATION MIN.

WIND DESIGN  
SEISMIC DESIGN

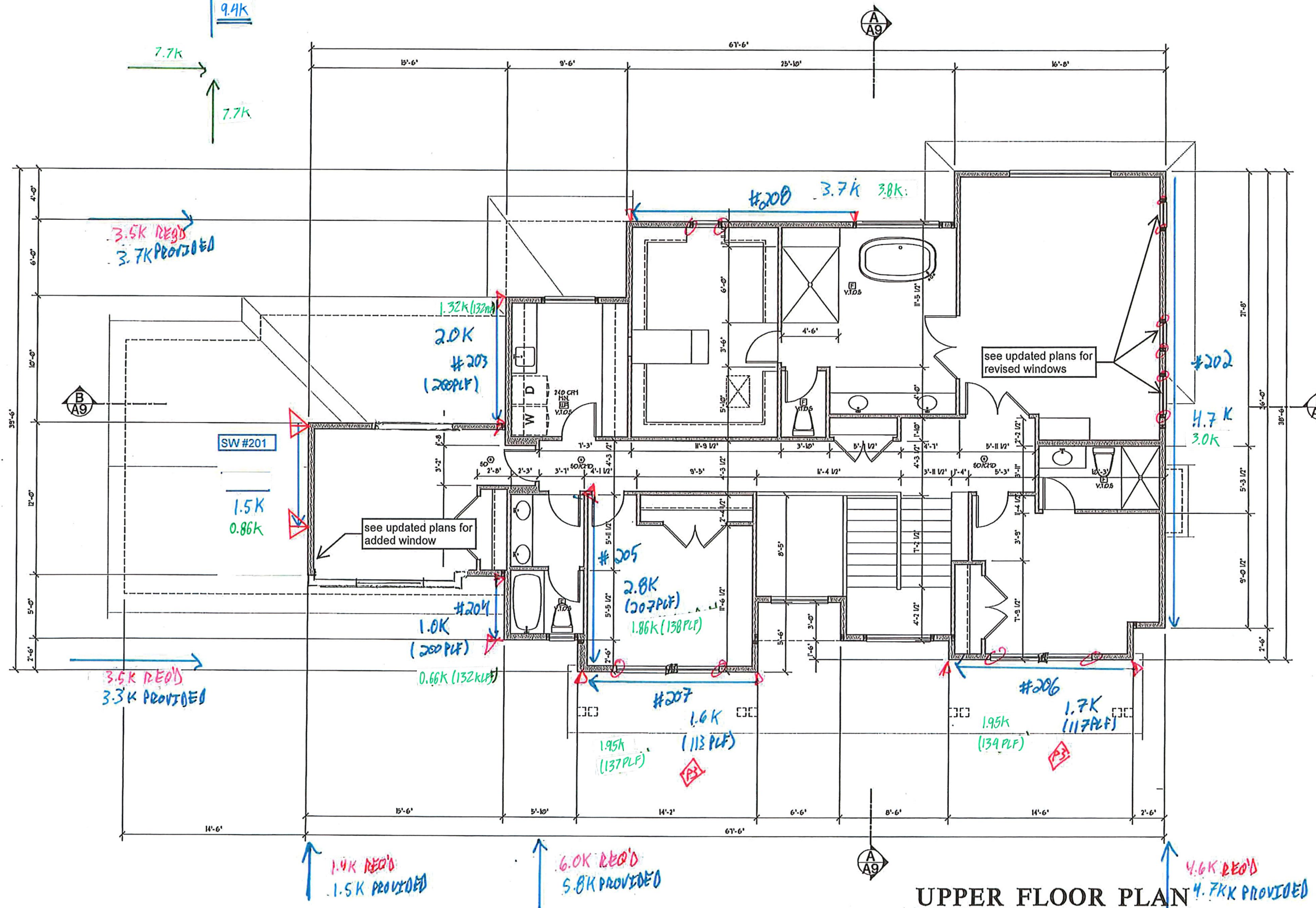
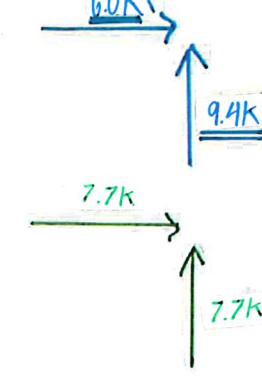

**UPPER FLOOR PLAN**  
Scale 1/4"=1'-0"

Date	By	Description
09/27/18	SM	PRELIMINARY DESIGN
10/02/18	SM	ELEVATION DESIGN
10/22/18	SM	DESIGN REVISIONS
12/12/18	REY	KITCHEN REVISIONS
12/20	SM	ELEVATION DESIGN

**Pratt Plat**  
7233 80th Ave SE  
Mercer Island, WA 98040  
THIS DRAWING IS © COPYRIGHTED ARCHITECTURAL INNOVATIONS, P.S. ALL RIGHTS RESERVED

**ARCHITECTURAL INNOVATIONS, P.S.**  
Forward Thinking Design Solutions For Your Environment  
14311 SE 16th St  
Bellevue, WA 98007  
1-800-888-4517  
www.archinnovationsps.com

TITLE
JOB NO.: 1903705
STARTING NO.: 1903705

SHEET  
**A5**

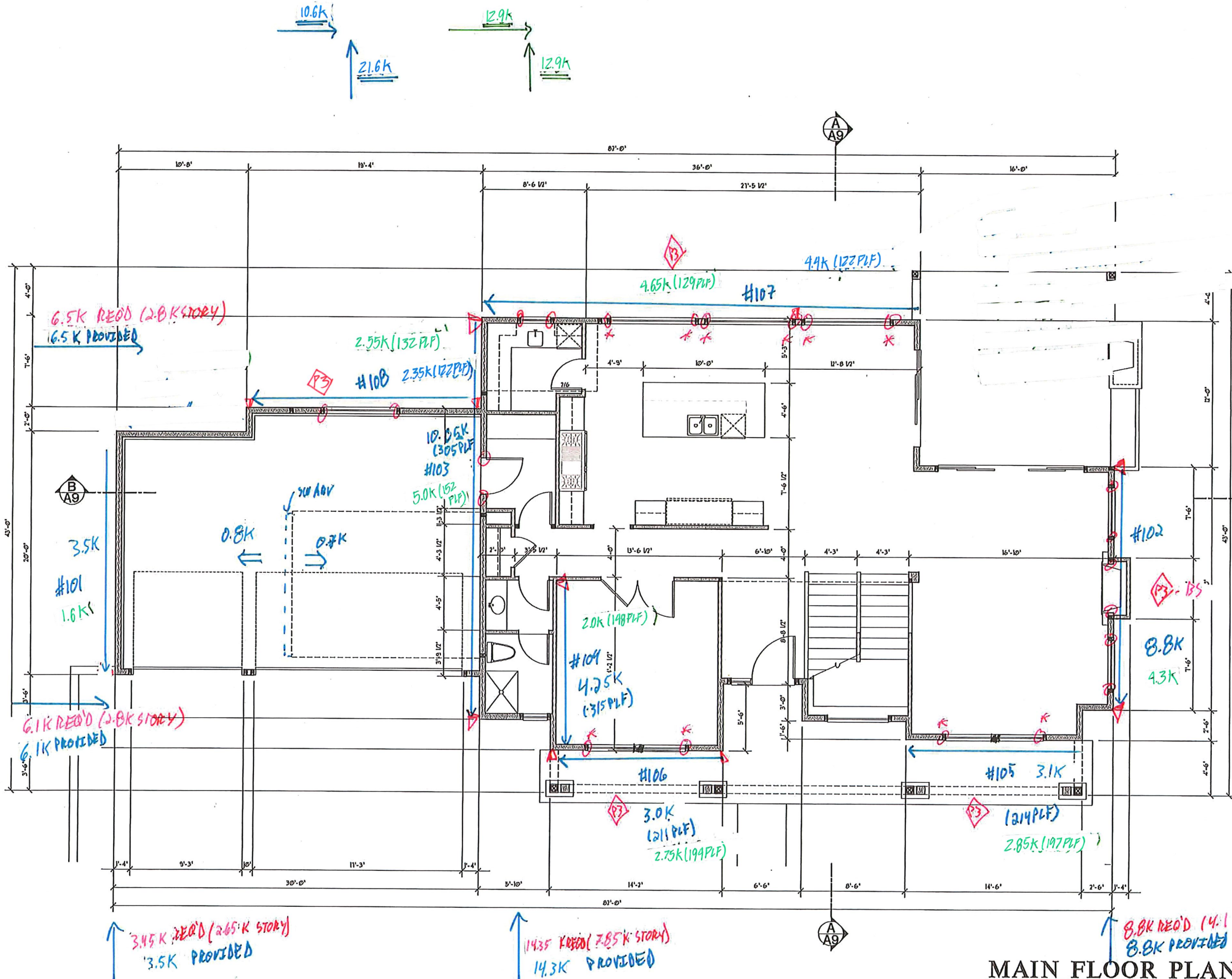

**GENERAL PLAN NOTES**

1. SEE SHEET A-1 FOR ALL GENERAL NOTES AND REQUIREMENTS.
2. ENERGY AND AIR QUALITY INFORMATION SEE DIV. 11 SHEET A-1
3. SEE BUILDING ELEVATION FOR WINDOW OPERATION SEE DIV. 8 SHEET A-1
4. SEE TYP. MATERIALS LIST ON SECTION SHEET
5. SEE SHEET A-1 FOR ALL NOTES AND REQUIREMENTS CONCERNING MECHANICAL, PLUMBING, AND ELECTRICAL.

**FLOOR PLAN KEY NOTES**

- P-1** OCCUPANCY SEPARATION. APPLY (1) LAYER OF 1/2" GIBB. TO GARAGE SIDE OF RESIDENCE, ATTIC SPACES, AND TO ALL BEAMS AND POSTS SUPPORTING A FLOOR-CEILING ASSEMBLY. APPLY (1) LAYER OF 1/2" TYPE "X" GIBB. TO GARAGE CEILING WHEN UNDER HABITABLE ROOFS. DUCTS THROUGH WALL OR CEILING COFFIN TO HOUSE SHALL HAVE MINIMUM 76 GAUGE STEEL. SEE DIV. 010276.A. SHEET A-1.
- P-2** 1/4" MIN. SELF CLOSING SOLID WOOD CORE, HONEY-COMB CORE STEEL, OR 20-MINUTE FIRE RATED DOOR. SEE DIV. 010276.B. SHEET A-1.
- P-3** STAIR ASSEMBLY NOTES: PER IRC, SECTION R301.5 AND DETAIL 17/D2.
  - A. HEADROOM MIN. 6'-8", WIDTH MIN. 3'-0".
  - B. TREADS 10" MIN. DEPTH AND MIN. WIDTH OF 36" ABOVE HANDRAIL. HEIGHT, RISERS 7/8" MAX. HT. TREAD NOSING TO BE MINIMUM 3/4" AND A MAXIMUM OF 1/4" ON STAIRS WITH SOLID RISERS.
  - C. HANDRAIL MIN. 34" TO MAX 38" ABOVE TREAD NOSING. HANDRAIL TYPE I CIRCULAR TO HAVE 1 1/2" MIN. TO 2" MAX. CROSS SECTION DIMENSION AND 1 1/2" MIN. CLEAR FROM WALL. RETURN RAIL ENDS. HANDRAILS SHALL BE STRONG ENOUGH TO RESIST A 200 LBS. POINT LOAD IN ANY DIRECTION PER IRC, TABLE R301.5.
  - D. INSTALL FIRE BLOCKS BETWEEN STRINGERS AT THE TOP AND BOTTOM OF EACH RUN PER IRC, SECTION R302.1.
  - E. COVER USABLE SPACE UNDER STAIR W/ 1/2" GIBB. PER IRC, SECTION R302.1.
  - F. INTERMEDIATE BALUSTERS SHALL BE SPACED W/ LESS THAN 4" BETWEEN BALUSTERS.
  - G. PROVIDE STAIRWAY ILLUMINATION PER IRC, SECTION R303.6. SEE DIV. 0907.1 SHEET A-1.
- P-4** SAFETY GLAZING PER IRC, SECTION R308.
  - A. WINDOWS WITHIN 18" OF FLOOR.
  - B. WINDOWS WITHIN A 24" ARC OF DOORS.
  - C. WINDOWS AT TUBS AND SHOWERS.
  - D. GLAZING IN DOORS.
  - E. LESS THAN 60" HORIZ. FROM THE BOT. STAIR TREAD NOSING, 1 BOT. EDGE OF GLAZING IS LESS THAN 36" ABV. LANDING/WALKING SURFACE. SEE DIV. 0802.0 SHEET A-1.
- P-5** EGRESS WINDOW PER IRC, SECTION R310. SEE DIV. 0802.0 SHEET A-1.
- P-6** IGNITERS FOR GAS FIRED APPLIANCES IN GARAGE TO BE 1/2" MIN. ABOVE TOP OF SLAB. SEE DIV. 15 SHEET A-1.
- P-7** COVER WALLS ADJACENT TO TUBS AND SHOWERS WITH NON-ABSORBENT MATERIAL TO 1/2" ABOVE DRAIN INLETS, PER IRC, SECTION 3012. SEE DIV. 0905.0 SHEET A-1.
- P-8** (2) LAYERS OF FLOOR SHEATHING OVER FRAMING.
- P-9** 1/4" MAX. RISER WITH 10" MIN. RUN IF MORE THAN (3) RISERS. HANDRAIL REQUIRED PER IRC, SECTION R301.4. SEE DIV. 0102.1 SHEET A-1.
- P-10** 10"x24" CRAWL SPACE ACCESS. INSULATE AND WEATHER STRIP. SEE DIV. 0102.1 SHEET A-1.
- P-11** 22"x30" ATTIC SPACE ACCESS W/ 30" HEAD CLEARANCE. INSULATE AND WEATHER STRIP. SEE DIV. 0102.2 SHEET A-1.
- P-12** FLOOR MATERIAL BREAK LINE
- P-13** WALL LINE ABOVE
- P-14** WALL LINE BELOW
- P-15** FIREPLACE ASSEMBLY NOTES:
  - A. DIRECT VENT GAS FIREPLACES, MUST BE LISTED, LABELED, INSTALLED PER MFG. SPECIFICATIONS, SHALL CONFORM TO IRC REQUIREMENTS. SEE DIV. 0102.1 SHEET A-1.
  - B. ZERO CLEARANCE FIREPLACES SHALL CONFORM TO IRC REQUIREMENTS. SEE DIV. 0102.1 SHEET A-1.
  - C. HEARTH SHALL CONFORM TO IRC REQUIREMENT SEE DIV. 0102.1 SHEET A-1.
  - D. FIREBLOCK OPENINGS AROUND PENETRATIONS
  - E. EACH FLOOR PER IRC, SECTION R303.5.
  - F. FIREPLACE MUST COMPLY WITH UL 121 TESTING
- P-16** SEE SITE PLAN FOR EXTENT OF WALKS & DRIVEWAYS
- P-17** 3" DIAMETER STEEL POST
- P-18** 36" GUARDRAIL PER IRC, SECTION R301.1 TABLE R301.5 CONTRACTOR TO VERIFY TO INSPECTOR THAT ALL GUARDS & RAILINGS ARE CAPABLE OF RESISTING 200 LBS. LOAD ON TOP RAIL ACTING IN ANY DIRECTION.
- P-19** 1" VENT FOR MECHANICAL. 1" CLEARANCE ALL SIDES PER IRC, SECTION R302.1 SEE DIV. 15 SHEET A-1
- P-20** PLANT SHELF
- P-21** UPPER AND LOWER LINEN CABINETS
- P-22** SOFFIT AREA
- P-23** INTEGRATED MAKE UP AIR
- P-24** 2x6 STUDS W/ R-21 INSULATION MIN.

Date	By	Description
02/27/20	SA	PRELIMINARY DESIGN
02/27/20	SA	ELEVATION DESIGN
02/27/20	SA	DESIGN REVISIONS
02/27/20	BSY	KITCHEN REVISIONS
02/27/20	SA	ELEVATION DESIGN

**Pratt Plat**  
 Lot 4  
 7233 80th Ave SE  
 Mercer Island, WA 98040

THIS DRAWING IS © COPYRIGHTED ARCHITECTURAL INNOVATIONS, P.S. ALL RIGHTS RESERVED

**ARCHITECTURAL INNOVATIONS, P.S.**  
 Forward Thinking Design Solutions For Your Environment  
 14311 SE 16th St  
 Bellevue, WA 98007  
 1-800-888-4517  
 www.architecturalinnovations.com

TITLE	
JOB NO. 1	1903703
STARTING NO. 1	1903703

SHEET  
A3

SQUARE FOOTAGE	
MAIN FLOOR	1558 SF
UPPER FLOOR	1791 SF
LOWER FLOOR	1278 SF
<b>TOTAL</b>	<b>4622 SF</b>
GARAGE	639 SF
PORCH	224 SF
PATIO	259 SF

**MAIN FLOOR PLAN**  
 Scale 1/4"=1'-0"

**GENERAL PLAN NOTES**

- SEE SHEET A-1 FOR ALL GENERAL NOTES AND REQUIREMENTS.
- ENERGY AND AIR QUALITY INFORMATION SEE DIV. 11 SHEET A-1
- SEE BUILDING ELEVATION FOR WINDOW OPERATION SEE DIV. 8 SHEET A-1
- SEE TYP. MATERIALS LIST ON SECTION SHEET
- SEE SHEET A-1 FOR ALL NOTES AND REQUIREMENTS CONCERNING MECHANICAL, PLUMBING, AND ELECTRICAL.

**FLOOR PLAN KEY NOTES**

- P-1 OCCUPANCY SEPARATION: APPLY (1) LAYER OF 1/2" GWB. TO GARAGE SIDE OF RESIDENCE, ATTIC SPACES, AND TO ALL BEAMS AND POSTS SUPPORTING A FLOOR-CEILING ASSEMBLY. APPLY (2) LAYER OF 1/2" TYPE "X" GWB. TO GARAGE CEILING WHEN UNDER HABITABLE ROOMS. DUCTS THROUGH WALL OR CEILING COMMON TO HOUSE SHALL HAVE MINIMUM 26 GAUGE STEEL. SEE DIV. 01007.6.A SHEET A-1
- P-2 1 1/2" MIN. SELF-CLOSING SOLID WOOD CORE, HONEY-COMB CORE STEEL, OR 20-MINUTE FIRE RATED DOOR. SEE DIV. 01007.6.B SHEET A-1
- P-3 STAIR ASSEMBLY NOTES: PER IRC, SECTION R301.5 AND DETAIL 1027.
  - A. HEADROOM MIN. 6'-8", WIDTH MIN. 3'-0".
  - B. TREADS 10" MIN. DEPTH AND MIN. WIDTH OF 36" ABOVE HANDRAIL HEIGHT, RISERS 7/8" MAX. HT. TREAD NOSING TO BE MINIMUM 3/4" AND A MAXIMUM OF 1/4" ON STAIRS WITH SOLID RISERS.
  - C. HANDRAIL MIN. 34" TO MAX. 38" ABOVE TREAD NOSING. HANDRAIL TYPE I CIRCULAR TO HAVE 1 1/4" MIN. TO 2" MAX. CROSS SECTION DIMENSION AND 1 1/2" MIN. CLEAR FROM WALL, RETURN RAIL ENDS. HANDRAILS SHALL BE STRONG ENOUGH TO RESIST A 200 LBS POINT LOAD IN ANY DIRECTION PER IRC, TABLE R301.5 D.
  - D. INSTALL FIRE BLOCKING BETWEEN STRINGERS AT THE TOP AND BOTTOM OF EACH RUN PER IRC, SECTION R307.1
  - E. COVER USABLE SPACE UNDER STAIR W 1/2" GWB. PER IRC, SECTION R307.1
  - F. INTERMEDIATE BALUSTERS SHALL BE SPACED W/ LESS THAN 4" BETWEEN BALUSTERS.
  - G. PROVIDE STAIRWAY ILLUMINATION PER IRC, SECTION R303.6. SEE DIV. 01007.1 SHEET A-1
- P-4 SAFETY GLAZING PER IRC, SECTION R308
  - A. WINDOWS WITHIN 18" OF FLOOR
  - B. WINDOWS WITHIN A 74" ARC OF DOORS
  - C. WINDOWS AT TUBS AND SHOWERS
  - D. GLAZING IN DOORS
  - E. LESS THAN 60" HORIZ. FROM THE BOT. STAIR TREAD NOSING, 1 BOT. EDGE OF GLAZING IS LESS THAN 36" ABV. LANDING/WALKING SURFACE. SEE DIV. 01007.1 SHEET A-1
- P-5 EGRESS WINDOW PER IRC, SECTION R310 SEE DIV. 01007.0 SHEET A-1
- P-6 IGNITERS FOR GAS FIRED APPLIANCES IN GARAGE TO BE 18" MIN. ABOVE TOP OF SLAB. SEE DIV. 10 SHEET A-1
- P-7 COVER WALLS ADJACENT TO TUBS AND SHOWERS WITH NON-ABSORBENT MATERIAL TO 1' ABOVE DRAIN INLETS, PER IRC, SECTION 3012. SEE DIV. 09150 SHEET A-1
- P-8 (2) LAYERS OF FLOOR SHEATHING OVER FRAMING.
- P-9 7/8" MAX. RISER WITH 10" MIN. RUN. IF MORE THAN (3) RISERS, HANDRAIL REQUIRED PER IRC, SECTION R301.5. SEE DIV. 01007.1 SHEET A-1
- P-10 18"x24" CRAIL SPACE ACCESS, INSULATE AND WEATHER STRIP. SEE DIV. 01007.1 SHEET A-1
- P-11 22"x30" ATTIC SPACE ACCESS W/ 30" HEAD CLEARANCE, INSULATE AND WEATHER STRIP. SEE DIV. 01007.2 SHEET A-1
- P-12 FLOOR MATERIAL BREAK LINE
- P-13 WALL LINE ABOVE
- P-14 WALL LINE BELOW
- P-15 FIREPLACE ASSEMBLY NOTES:
  - A. DIRECT VENT GAS FIREPLACES, MUST BE LISTED, LABELED (INSTALLED PER IFG. SPECIFICATIONS, SHALL CONFORM TO IRC REQUIREMENTS. SEE DIV. 01007.1 SHEET A-1
  - B. ZERO CLEARANCE FIREPLACES SHALL CONFORM TO IRC, REQUIREMENTS. SEE DIV. 01007.1 SHEET A-1
  - C. HEARTH SHALL CONFORM TO IRC REQUIREMENT SEE DIV. 01007.1
  - D. FIREBLOCK OPENINGS AROUND PENETRATIONS @ EACH FLOOR PER IRC, SECTION R1003.3
  - E. FIREPLACE MUST COMPLY WITH UL 117 TESTING
- P-16 SEE SITE PLAN FOR EXTENT OF WALKS & DRIVEWAYS
- P-17 3" DIAMETER STEEL POST
- P-18 36" GUARDRAIL PER IRC, SECTION R302 & TABLE R302.5 CONTRACTOR TO VERIFY TO INSPECTOR THAT ALL GUARDS & RAILINGS ARE CAPABLE OF RESISTING 200 LBS LOAD ON TOP RAIL ACTING IN ANY DIRECTION
- P-19 18" VENT FOR MECHANICAL, 1" CLEARANCE ALL SIDES PER IRC, SECTION R302.1 SEE DIV. 15 SHEET A-1
- P-20 PLANT SHELVE
- P-21 UPPER AND LOWER LINEN CABINETS
- P-22 SOFFIT AREA
- P-23 INTEGRATED MAKE UP AIR
- P-24 2x6 STUDS W/ R-21 INSULATION MIN.

Date	By	Description
	SA	PRELIMINARY DESIGN
	SA	FOUNDATION DESIGN
	SA	DESIGN REVISION
	SA	DESIGN REVISION
	SA	DESIGN REVISION
	SA	ELEMENT DESIGN

**Pratt Plat**  
 Lot 4  
 7233 80th Ave SE  
 Mercer Island, WA 98040  
 THIS DRAWING IS © COPYRIGHTED ARCHITECTURAL INNOVATIONS, P.S. ALL RIGHTS RESERVED

**ARCHITECTURAL INNOVATIONS, P.S.**  
 Forward Thinking Design Solutions For Your Environment  
 14311 SE 16th St.  
 Bellevue, WA 98007  
 1-800-888-4517  
 www.archinnovations.com

TITLE
LOWER FLOOR PLAN
JOB NO.: 1107103
STARTING NO.: 1107103
SHEET
<b>A2.1</b>

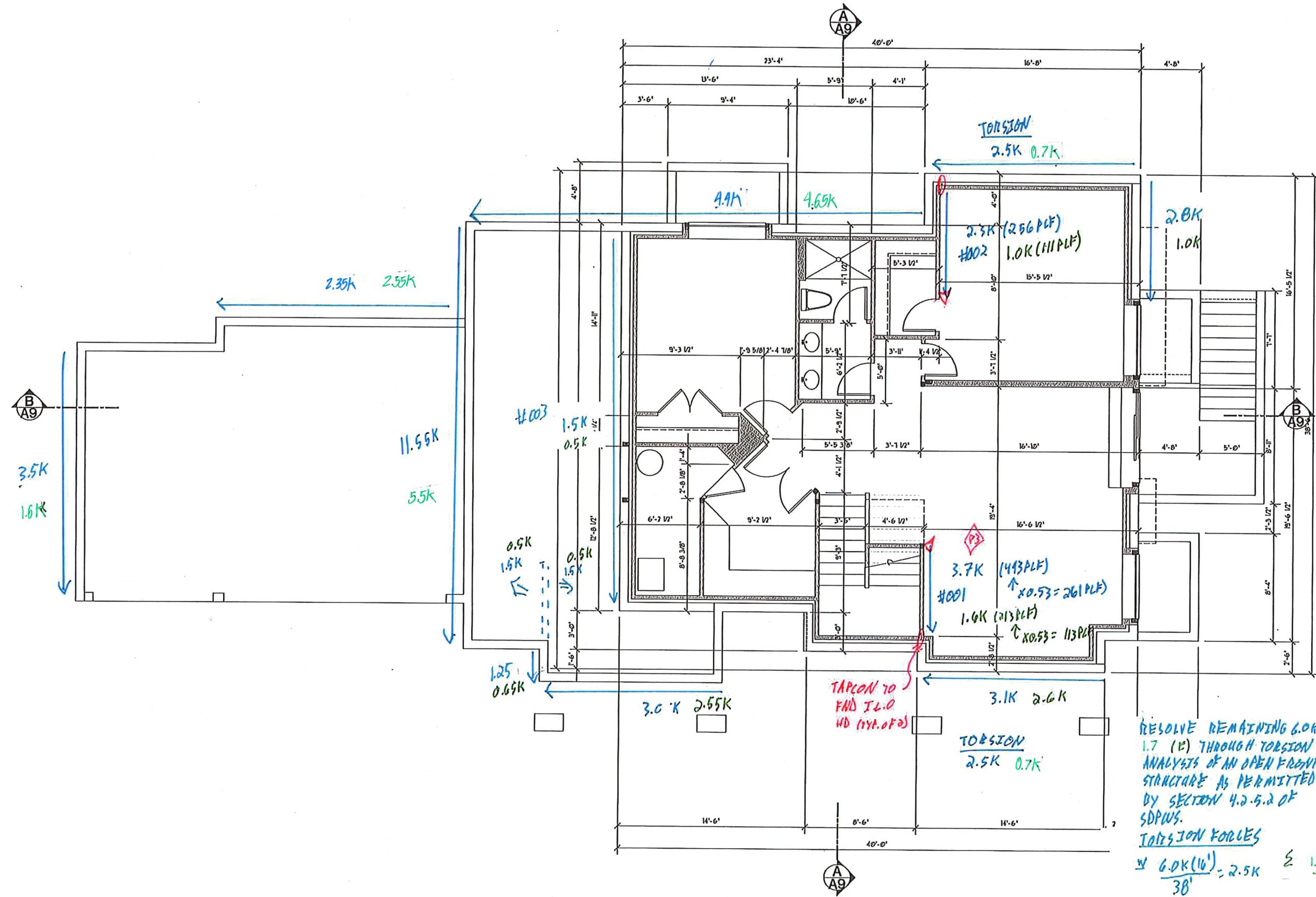

**LOWER FLOOR PLAN**  
 Scale: 1/4" = 1'-0"





**SHEARWALL DESIGN SUMMARY**

**SHEARWALL 201:** 2ND - SIDE EXT. WALL @ BED 4

**SHEARWALL PROPERTIES:**

WALL HEIGHT, H  FT.      MAX WALL OPENING HT, H<sub>c</sub>  FT.  
WALL LENGTH, L  FT.      QUALIFYING WALL LENGTH, L  FT.      SHEARWALL ASSEMBLY

**CAPACITY EVALUATION:**

TOTAL SHEAR LOAD ON WALL  LBS < ALLOWABLE SHEARWALL CAPACITY  LBS

**SHEARWALL ASSEMBLY SPECIFICATION**

P1 - 1-SIDE 7/16" OSB  
FASTENED W/ 8D NAILS AT 6"O.C. PANEL EDGES & 12"O.C. PANEL FIELD - EDGES BLOCKED  
**ADEQUATE**

**OVERTURNING EVALUATION:**

RESISTIVE DL  PLF      OVERTURNING MOMENT  K-FT      HOLD DOWN DESIGN LOAD  LBS  
DL AT ENDS OF WALL  LBS      RESISTIVE MOMENT  K-FT      HOLDDOWN CAPACITY  LBS

**HOLD-DOWN SPECIFICATION**

**SIMPSON CS 16 STRAP TIE (14" END LENGTH)**

**SHEARWALL 202:** 2ND - SIDE EXT. WALL @ MASTER BED TO BED 2

**SHEARWALL PROPERTIES:**

WALL HEIGHT, H  FT.      MAX WALL OPENING HT, H<sub>c</sub>  FT.  
WALL LENGTH, L  FT.      QUALIFYING WALL LENGTH, L  FT.      SHEARWALL ASSEMBLY

**CAPACITY EVALUATION:**

TOTAL SHEAR LOAD ON WALL  LBS < ALLOWABLE SHEARWALL CAPACITY  LBS

**SHEARWALL ASSEMBLY SPECIFICATION**

P1 - 1-SIDE 7/16" OSB  
FASTENED W/ 8D NAILS AT 6"O.C. PANEL EDGES & 12"O.C. PANEL FIELD - EDGES BLOCKED  
**ADEQUATE**

**OVERTURNING EVALUATION:**

RESISTIVE DL  PLF      OVERTURNING MOMENT  K-FT      HOLD DOWN DESIGN LOAD  LBS  
DL AT ENDS OF WALL  LBS      RESISTIVE MOMENT  K-FT      HOLDDOWN CAPACITY  LBS

**HOLD-DOWN SPECIFICATION**

**NO HOLDDOWN REQUIRED**



**SHEARWALL DESIGN SUMMARY**

**SHEARWALL 203:** 2ND - SIDE EXT. WALL @ UTILITY

**SHEARWALL PROPERTIES:**

WALL HEIGHT, H  FT.      MAX WALL OPENING HT, H<sub>c</sub>  FT.  
WALL LENGTH, L  FT.      QUALIFYING WALL LENGTH, L  FT.      SHEARWALL ASSEMBLY

**CAPACITY EVALUATION:**

TOTAL SHEAR LOAD ON WALL  LBS < ALLOWABLE SHEARWALL CAPACITY  LBS

**SHEARWALL ASSEMBLY SPECIFICATION**

P1 - 1-SIDE 7/16" OSB  
FASTENED W/ 8D NAILS AT 6"O.C. PANEL EDGES & 12"O.C. PANEL FIELD - EDGES BLOCKED  
**ADEQUATE**

**OVERTURNING EVALUATION:**

RESISTIVE DL  PLF      OVERTURNING MOMENT  K-FT      UPLIFT CONNECTOR DESIGN LOAD  LBS  
DL AT ENDS OF WALL  LBS      RESISTIVE MOMENT  K-FT      HOLDOWN CAPACITY  LBS

**HOLD-DOWN SPECIFICATION**

**SIMPSON CS 16 STRAP TIE (14" END LENGTH)**

**SHEARWALL 204:** 2ND - SIDE EXT. WALL @ BATH

**SHEARWALL PROPERTIES:**

WALL HEIGHT, H  FT.      MAX WALL OPENING HT, H<sub>c</sub>  FT.  
WALL LENGTH, L  FT.      QUALIFYING WALL LENGTH, L  FT.      SHEARWALL ASSEMBLY

**CAPACITY EVALUATION:**

TOTAL SHEAR LOAD ON WALL  LBS < ALLOWABLE SHEARWALL CAPACITY  LBS

**SHEARWALL ASSEMBLY SPECIFICATION**

P1 - 1-SIDE 7/16" OSB  
FASTENED W/ 8D NAILS AT 6"O.C. PANEL EDGES & 12"O.C. PANEL FIELD - EDGES BLOCKED  
**ADEQUATE**

**OVERTURNING EVALUATION:**

RESISTIVE DL  PLF      OVERTURNING MOMENT  K-FT      HOLD DOWN DESIGN LOAD  LBS  
DL AT ENDS OF WALL  LBS      RESISTIVE MOMENT  K-FT      HOLDOWN CAPACITY  LBS

**HOLD-DOWN SPECIFICATION**

**SIMPSON CS 16 STRAP TIE (14" END LENGTH)**



**SHEARWALL DESIGN SUMMARY**

**SHEARWALL 205:** 2ND - SIDE INT. WALL @ BED 3

**SHEARWALL PROPERTIES:**

WALL HEIGHT, H	<input type="text" value="9.0"/>	FT.	MAX WALL OPENING HT, H <sub>c</sub>	<input type="text" value="0.0"/>	FT.		
WALL LENGTH, L	<input type="text" value="13.5"/>	FT.	QUALIFYING WALL LENGTH, L	<input type="text" value="13.5"/>	FT.	SHEARWALL ASSEMBLY	<input type="text" value="P1"/>

**CAPACITY EVALUATION:**

TOTAL SHEAR LOAD ON WALL	<input type="text" value="2800"/>	LBS	<	ALLOWABLE SHEARWALL CAPACITY	<input type="text" value="4536"/>	LBS
--------------------------	-----------------------------------	-----	---	------------------------------	-----------------------------------	-----

**SHEARWALL ASSEMBLY SPECIFICATION**

P1 - 1-SIDE 7/16" OSB  
FASTENED W/ 8D NAILS AT 6"D.C. PANEL EDGES & 12"D.C. PANEL FIELD - EDGES BLOCKED  
**ADEQUATE**

**OVERTURNING EVALUATION:**

RESISTIVE DL	<input type="text" value="100"/>	PLF	OVERTURNING MOMENT	<input type="text" value="25.2"/>	K-FT	UPLIFT CONNECTOR DESIGN LOAD	<input type="text" value="1222"/>	LBS
DL AT ENDS OF WALL	<input type="text" value="400"/>	LBS	RESISTIVE MOMENT	<input type="text" value="8.7"/>	K-FT	HOLDOWN CAPACITY	<input type="text" value="1705"/>	LBS

**HOLD-DOWN SPECIFICATION**

**SIMPSON CS 16 STRAP TIE (14" END LENGTH)**

**SHEARWALL 206:** 2ND - FRONT EXT. WALL @ BED 2

**SHEARWALL PROPERTIES:**

WALL HEIGHT, H	<input type="text" value="9.0"/>	FT.	MAX WALL OPENING HT, H <sub>c</sub>	<input type="text" value="5.5"/>	FT.		
WALL LENGTH, L	<input type="text" value="14.5"/>	FT.	QUALIFYING WALL LENGTH, L	<input type="text" value="7.0"/>	FT.	SHEARWALL ASSEMBLY	<input type="text" value="P1"/>

**CAPACITY EVALUATION:**

TOTAL SHEAR LOAD ON WALL	<input type="text" value="1700"/>	LBS	<	ALLOWABLE SHEARWALL CAPACITY	<input type="text" value="2352"/>	LBS
--------------------------	-----------------------------------	-----	---	------------------------------	-----------------------------------	-----

**SHEARWALL ASSEMBLY SPECIFICATION**

P1 - 1-SIDE 7/16" OSB  
FASTENED W/ 8D NAILS AT 6"D.C. PANEL EDGES & 12"D.C. PANEL FIELD - EDGES BLOCKED  
**ADEQUATE**

**OVERTURNING EVALUATION:**

RESISTIVE DL	<input type="text" value="134"/>	PLF	OVERTURNING MOMENT	<input type="text" value="15.3"/>	K-FT	HOLD DOWN DESIGN LOAD	<input type="text" value="0"/>	LBS
DL AT ENDS OF WALL	<input type="text" value="800"/>	LBS	RESISTIVE MOMENT	<input type="text" value="15.4"/>	K-FT	HOLDOWN CAPACITY	<input type="text" value="0"/>	LBS

**HOLD-DOWN SPECIFICATION**

**NO HOLDOWN REQUIRED**



**SHEARWALL DESIGN SUMMARY**

**SHEARWALL 207:** 2ND - FRONT EXT. WALL @ BED 3

**SHEARWALL PROPERTIES:**

WALL HEIGHT, H  FT.      MAX WALL OPENING HT, H<sub>c</sub>  FT.  
WALL LENGTH, L  FT.      QUALIFYING WALL LENGTH, L  FT.      SHEARWALL ASSEMBLY

**CAPACITY EVALUATION:**

TOTAL SHEAR LOAD ON WALL  LBS < ALLOWABLE SHEARWALL CAPACITY  LBS

**SHEARWALL ASSEMBLY SPECIFICATION**

P1 - 1-SIDE 7/16" OSB  
FASTENED W/ 8D NAILS AT 6"O.C. PANEL EDGES & 12"O.C. PANEL FIELD - EDGES BLOCKED  
**ADEQUATE**

**OVERTURNING EVALUATION:**

RESISTIVE DL  PLF      OVERTURNING MOMENT  K-FT      UPLIFT CONNECTOR DESIGN LOAD  LBS  
DL AT ENDS OF WALL  LBS      RESISTIVE MOMENT  K-FT      HOLDOWN CAPACITY  LBS

**HOLD-DOWN SPECIFICATION**

**NO HOLDOWN REQUIRED**

**SHEARWALL 208:** 2ND - REAR EXT. WALL @ MASTER BATH TO WIC

**SHEARWALL PROPERTIES:**

WALL HEIGHT, H  FT.      MAX WALL OPENING HT, H<sub>c</sub>  FT.  
WALL LENGTH, L  FT.      QUALIFYING WALL LENGTH, L  FT.      SHEARWALL ASSEMBLY

**CAPACITY EVALUATION:**

TOTAL SHEAR LOAD ON WALL  LBS < ALLOWABLE SHEARWALL CAPACITY  LBS

**SHEARWALL ASSEMBLY SPECIFICATION**

P1 - 1-SIDE 7/16" OSB  
FASTENED W/ 8D NAILS AT 6"O.C. PANEL EDGES & 12"O.C. PANEL FIELD - EDGES BLOCKED  
**ADEQUATE**

**OVERTURNING EVALUATION:**

RESISTIVE DL  PLF      OVERTURNING MOMENT  K-FT      HOLD DOWN DESIGN LOAD  LBS  
DL AT ENDS OF WALL  LBS      RESISTIVE MOMENT  K-FT      HOLDOWN CAPACITY  LBS

**HOLD-DOWN SPECIFICATION**

**NO HOLDOWN REQUIRED**



**SHEARWALL DESIGN SUMMARY**

**SHEARWALL XXX:** - NOT USED

**SHEARWALL PROPERTIES:**

WALL HEIGHT, H  FT. MAX WALL OPENING HT, H<sub>c</sub>  FT.  
WALL LENGTH, L  FT. QUALIFYING WALL LENGTH, L  FT. SHEARWALL ASSEMBLY

**CAPACITY EVALUATION:**

TOTAL SHEAR LOAD ON WALL  LBS ALLOWABLE SHEARWALL CAPACITY  LBS

**SHEARWALL ASSEMBLY SPECIFICATION**

P1 - 1-SIDE 7/16" OSB  
FASTENED W/ 8D NAILS AT 6"O.C. PANEL EDGES & 12"O.C. PANEL FIELD - EDGES BLOCKED

**OVERTURNING EVALUATION:**

RESISTIVE DL  PLF OVERTURNING MOMENT  K-FT UPLIFT CONNECTOR DESIGN LOAD  LBS  
DL AT ENDS OF WALL  LBS RESISTIVE MOMENT  K-FT HOLDOWN CAPACITY  LBS

**HOLD-DOWN SPECIFICATION**

NO HOLDOWN REQUIRED

**SHEARWALL 101:** 1ST - SIDE EXT. WALL @ GARAGE

**SHEARWALL PROPERTIES:**

WALL HEIGHT, H  FT. MAX WALL OPENING HT, H<sub>c</sub>  FT.  
WALL LENGTH, L  FT. QUALIFYING WALL LENGTH, L  FT. SHEARWALL ASSEMBLY

**CAPACITY EVALUATION:**

TOTAL SHEAR LOAD ON WALL  LBS ALLOWABLE SHEARWALL CAPACITY  LBS  
<

**SHEARWALL ASSEMBLY SPECIFICATION**

P1 - 1-SIDE 7/16" OSB  
FASTENED W/ 8D NAILS AT 6"O.C. PANEL EDGES & 12"O.C. PANEL FIELD - EDGES BLOCKED  
**ADEQUATE**

**OVERTURNING EVALUATION:**

RESISTIVE DL  PLF OVERTURNING MOMENT  K-FT HOLD DOWN DESIGN LOAD  LBS  
DL AT ENDS OF WALL  LBS RESISTIVE MOMENT  K-FT HOLDOWN CAPACITY  LBS

**HOLD-DOWN SPECIFICATION**

NO HOLDOWN REQUIRED



**SHEARWALL DESIGN SUMMARY**

**SHEARWALL 102:** 1ST - SIDE EXT. WALL @ GREAT ROOM

**SHEARWALL PROPERTIES:**

WALL HEIGHT, H  FT.      MAX WALL OPENING HT, H<sub>c</sub>  FT.  
WALL LENGTH, L  FT.      QUALIFYING WALL LENGTH, L  FT.      SHEARWALL ASSEMBLY

**CAPACITY EVALUATION:**

TOTAL SHEAR LOAD ON WALL  LBS < ALLOWABLE SHEARWALL CAPACITY  LBS

**SHEARWALL ASSEMBLY SPECIFICATION**

P3-BS - 2-SIDES 7/16" OSB  
FASTENED W/ 8D NAILS AT 3"D.C. PANEL EDGES & 12"D.C. PANEL FIELD - EDGES BLOCKED  
**ADEQUATE**

**OVERTURNING EVALUATION:**

RESISTIVE DL  PLF      OVERTURNING MOMENT  K-FT      UPLIFT CONNECTOR DESIGN LOAD  LBS  
DL AT ENDS OF WALL  LBS      RESISTIVE MOMENT  K-FT      HOLDOWN CAPACITY  LBS

**HOLD-DOWN SPECIFICATION**

**SIMPSON MSTC66 STRAP TIE (20" END LENGTH)**

**SHEARWALL 103:** 1ST - SIDE INT. WALL @ GARAGE

**SHEARWALL PROPERTIES:**

WALL HEIGHT, H  FT.      MAX WALL OPENING HT, H<sub>c</sub>  FT.  
WALL LENGTH, L  FT.      QUALIFYING WALL LENGTH, L  FT.      SHEARWALL ASSEMBLY

**CAPACITY EVALUATION:**

TOTAL SHEAR LOAD ON WALL  LBS < ALLOWABLE SHEARWALL CAPACITY  LBS

**SHEARWALL ASSEMBLY SPECIFICATION**

P1 - 1-SIDE 7/16" OSB  
FASTENED W/ 8D NAILS AT 6"D.C. PANEL EDGES & 12"D.C. PANEL FIELD - EDGES BLOCKED  
**ADEQUATE**

**OVERTURNING EVALUATION:**

RESISTIVE DL  PLF      OVERTURNING MOMENT  K-FT      HOLD DOWN DESIGN LOAD  LBS  
DL AT ENDS OF WALL  LBS      RESISTIVE MOMENT  K-FT      HOLDOWN CAPACITY  LBS

**HOLD-DOWN SPECIFICATION**

**SIMPSON STHD14RJ HOLDOWN**



**SHEARWALL DESIGN SUMMARY**

**SHEARWALL 104:** 1ST - SIDE EXT. WALL @ OFFICE

**SHEARWALL PROPERTIES:**

WALL HEIGHT, H  FT.      MAX WALL OPENING HT, H<sub>c</sub>  FT.  
WALL LENGTH, L  FT.      QUALIFYING WALL LENGTH, L  FT.      SHEARWALL ASSEMBLY

**CAPACITY EVALUATION:**

TOTAL SHEAR LOAD ON WALL  LBS < ALLOWABLE SHEARWALL CAPACITY  LBS

**SHEARWALL ASSEMBLY SPECIFICATION**

**P1 - 1-SIDE 7/16" OSB**  
FASTENED W/ 8D NAILS AT 6"O.C. PANEL EDGES & 12"O.C. PANEL FIELD - EDGES BLOCKED  
**ADEQUATE**

**OVERTURNING EVALUATION:**

RESISTIVE DL  PLF      OVERTURNING MOMENT  K-FT      UPLIFT CONNECTOR DESIGN LOAD  LBS  
DL AT ENDS OF WALL  LBS      RESISTIVE MOMENT  K-FT      HOLDOWN CAPACITY  LBS

**HOLD-DOWN SPECIFICATION**

**SIMPSON MSTC66 STRAP TIE (20" END LENGTH)**

**SHEARWALL 105:** 1ST - FRONT EXT. WALL @ GREAT ROOM

**SHEARWALL PROPERTIES:**

WALL HEIGHT, H  FT.      MAX WALL OPENING HT, H<sub>c</sub>  FT.  
WALL LENGTH, L  FT.      QUALIFYING WALL LENGTH, L  FT.      SHEARWALL ASSEMBLY

**CAPACITY EVALUATION:**

TOTAL SHEAR LOAD ON WALL  LBS < ALLOWABLE SHEARWALL CAPACITY  LBS

**SHEARWALL ASSEMBLY SPECIFICATION**

**P3 - 1-SIDE 7/16" OSB**  
FASTENED W/ 8D NAILS AT 3"O.C. PANEL EDGES & 12"O.C. PANEL FIELD - EDGES BLOCKED  
**ADEQUATE**

**OVERTURNING EVALUATION:**

RESISTIVE DL  PLF      OVERTURNING MOMENT  K-FT      HOLD DOWN DESIGN LOAD  LBS  
DL AT ENDS OF WALL  LBS      RESISTIVE MOMENT  K-FT      HOLDOWN CAPACITY  LBS

**HOLD-DOWN SPECIFICATION**

**NO HOLDOWN REQUIRED**



**SHEARWALL DESIGN SUMMARY**

**SHEARWALL 106:** 1ST - FRONT EXT. WALL @ OFFICE

**SHEARWALL PROPERTIES:**

WALL HEIGHT, H  FT.      MAX WALL OPENING HT, H<sub>c</sub>  FT.  
WALL LENGTH, L  FT.      QUALIFYING WALL LENGTH, L  FT.      SHEARWALL ASSEMBLY

**CAPACITY EVALUATION:**

TOTAL SHEAR LOAD ON WALL  LBS < ALLOWABLE SHEARWALL CAPACITY  LBS

**SHEARWALL ASSEMBLY SPECIFICATION**

**P3 - 1-SIDE 7/16" OSB**  
FASTENED W/ 8D NAILS AT 3"D.C. PANEL EDGES & 12"D.C. PANEL FIELD - EDGES BLOCKED  
**ADEQUATE**

**OVERTURNING EVALUATION:**

RESISTIVE DL  PLF      OVERTURNING MOMENT  K-FT      UPLIFT CONNECTOR DESIGN LOAD  LBS  
DL AT ENDS OF WALL  LBS      RESISTIVE MOMENT  K-FT      HOLDOWN CAPACITY  LBS

**HOLD-DOWN SPECIFICATION**

**SIMPSON STDH14RJ HOLDOWN**

**SHEARWALL 107:** 1ST - REAR EXT. WALL @ KITCHEN

**SHEARWALL PROPERTIES:**

WALL HEIGHT, H  FT.      MAX WALL OPENING HT, H<sub>c</sub>  FT.  
WALL LENGTH, L  FT.      QUALIFYING WALL LENGTH, L  FT.      SHEARWALL ASSEMBLY

**CAPACITY EVALUATION:**

TOTAL SHEAR LOAD ON WALL  LBS < ALLOWABLE SHEARWALL CAPACITY  LBS

**SHEARWALL ASSEMBLY SPECIFICATION**

**P3 - 1-SIDE 7/16" OSB**  
FASTENED W/ 8D NAILS AT 3"D.C. PANEL EDGES & 12"D.C. PANEL FIELD - EDGES BLOCKED  
**ADEQUATE**

**OVERTURNING EVALUATION:**

RESISTIVE DL  PLF      OVERTURNING MOMENT  K-FT      HOLD DOWN DESIGN LOAD  LBS  
DL AT ENDS OF WALL  LBS      RESISTIVE MOMENT  K-FT      HOLDOWN CAPACITY  LBS

**HOLD-DOWN SPECIFICATION**

**NO HOLDOWN REQUIRED**





**SHEARWALL DESIGN SUMMARY**

**SHEARWALL 108:** 1ST - REAR EXT. WALL @ GARAGE

**SHEARWALL PROPERTIES:**

WALL HEIGHT, H  FT.      MAX WALL OPENING HT, H<sub>c</sub>  FT.  
WALL LENGTH, L  FT.      QUALIFYING WALL LENGTH, L  FT.      SHEARWALL ASSEMBLY

**CAPACITY EVALUATION:**

TOTAL SHEAR LOAD ON WALL  LBS      <      ALLOWABLE SHEARWALL CAPACITY  LBS

**SHEARWALL ASSEMBLY SPECIFICATION**

**P3 - 1-SIDE 7/16" OSB**  
FASTENED W/ 8D NAILS AT 3"O.C. PANEL EDGES & 12"O.C. PANEL FIELD - EDGES BLOCKED  
**ADEQUATE**

**OVERTURNING EVALUATION:**

RESISTIVE DL  PLF      OVERTURNING MOMENT  K-FT      UPLIFT CONNECTOR DESIGN LOAD  LBS  
DL AT ENDS OF WALL  LBS      RESISTIVE MOMENT  K-FT      HOLDOWN CAPACITY  LBS

**HOLD-DOWN SPECIFICATION**

**SIMPSON STHD14RJ HOLDOWN**

**SHEARWALL XXX:** - NOT USED

**SHEARWALL PROPERTIES:**

WALL HEIGHT, H  FT.      MAX WALL OPENING HT, H<sub>c</sub>  FT.  
WALL LENGTH, L  FT.      QUALIFYING WALL LENGTH, L  FT.      SHEARWALL ASSEMBLY

**CAPACITY EVALUATION:**

TOTAL SHEAR LOAD ON WALL  LBS      ###      ALLOWABLE SHEARWALL CAPACITY  LBS

**SHEARWALL ASSEMBLY SPECIFICATION**

**P1 - 1-SIDE 7/16" OSB**  
FASTENED W/ 8D NAILS AT 6"O.C. PANEL EDGES & 12"O.C. PANEL FIELD - EDGES BLOCKED  
**#DIV/0!**

**OVERTURNING EVALUATION:**

RESISTIVE DL  PLF      OVERTURNING MOMENT  K-FT      HOLD DOWN DESIGN LOAD  LBS  
DL AT ENDS OF WALL  LBS      RESISTIVE MOMENT  K-FT      HOLDOWN CAPACITY  LBS

**HOLD-DOWN SPECIFICATION**

**NO HOLDOWN REQUIRED**



**SHEARWALL DESIGN SUMMARY**

**SHEARWALL 1: BASEMENT - SIDE INT. WALL @ STAIRS**

**SHEARWALL PROPERTIES:**

WALL HEIGHT, H  FT.      MAX WALL OPENING HT, H<sub>c</sub>  FT.  
WALL LENGTH, L  FT.      QUALIFYING WALL LENGTH, L  FT.      SHEARWALL ASSEMBLY

**CAPACITY EVALUATION:**

TOTAL SHEAR LOAD ON WALL  LBS < ALLOWABLE SHEARWALL CAPACITY  LBS

**SHEARWALL ASSEMBLY SPECIFICATION**

**P3 - 1-SIDE 7/16" OSB**  
FASTENED W/ 8D NAILS AT 3"D.C. PANEL EDGES & 12"D.C. PANEL FIELD - EDGES BLOCKED  
**ADEQUATE**

**OVERTURNING EVALUATION:**

RESISTIVE DL  PLF      OVERTURNING MOMENT  K-FT      UPLIFT CONNECTOR DESIGN LOAD  LBS  
DL AT ENDS OF WALL  LBS      RESISTIVE MOMENT  K-FT      HOLDOWN CAPACITY  LBS

**HOLD-DOWN SPECIFICATION**

**SIMPSON STHD14RJ HOLDOWN**

**SHEARWALL 2: BASEMENT - SIDE INT. WALL @ BED 5**

**SHEARWALL PROPERTIES:**

WALL HEIGHT, H  FT.      MAX WALL OPENING HT, H<sub>c</sub>  FT.  
WALL LENGTH, L  FT.      QUALIFYING WALL LENGTH, L  FT.      SHEARWALL ASSEMBLY

**CAPACITY EVALUATION:**

TOTAL SHEAR LOAD ON WALL  LBS < ALLOWABLE SHEARWALL CAPACITY  LBS

**SHEARWALL ASSEMBLY SPECIFICATION**

**P1 - 1-SIDE 7/16" OSB**  
FASTENED W/ 8D NAILS AT 6"D.C. PANEL EDGES & 12"D.C. PANEL FIELD - EDGES BLOCKED  
**ADEQUATE**

**OVERTURNING EVALUATION:**

RESISTIVE DL  PLF      OVERTURNING MOMENT  K-FT      HOLD DOWN DESIGN LOAD  LBS  
DL AT ENDS OF WALL  LBS      RESISTIVE MOMENT  K-FT      HOLDOWN CAPACITY  LBS

**HOLD-DOWN SPECIFICATION**

**SIMPSON STHD14RJ HOLDOWN**



**SHEARWALL DESIGN SUMMARY**

**SHEARWALL 3: BASEMENT - SIDE INT. WALL @ BASEMENT TO CRAWL**

**SHEARWALL PROPERTIES:**

WALL HEIGHT, H  FT. MAX WALL OPENING HT, H<sub>c</sub>  FT.  
WALL LENGTH, L  FT. QUALIFYING WALL LENGTH, L  FT. SHEARWALL ASSEMBLY

**CAPACITY EVALUATION:**

TOTAL SHEAR LOAD ON WALL  LBS < ALLOWABLE SHEARWALL CAPACITY  LBS

**SHEARWALL ASSEMBLY SPECIFICATION**

P1 - 1-SIDE 7/16" OSB  
FASTENED W/ 8D NAILS AT 6"O.C. PANEL EDGES & 12"O.C. PANEL FIELD - EDGES BLOCKED  
**ADEQUATE**

**OVERTURNING EVALUATION:**

RESISTIVE DL  PLF OVERTURNING MOMENT  K-FT UPLIFT CONNECTOR DESIGN LOAD  LBS  
DL AT ENDS OF WALL  LBS RESISTIVE MOMENT  K-FT HOLDOWN CAPACITY  LBS

**HOLD-DOWN SPECIFICATION**

**NO HOLDOWN REQUIRED**

**SHEARWALL XXX: - NOT USED**

**SHEARWALL PROPERTIES:**

WALL HEIGHT, H  FT. MAX WALL OPENING HT, H<sub>c</sub>  FT.  
WALL LENGTH, L  FT. QUALIFYING WALL LENGTH, L  FT. SHEARWALL ASSEMBLY

**CAPACITY EVALUATION:**

TOTAL SHEAR LOAD ON WALL  LBS ####! ALLOWABLE SHEARWALL CAPACITY  LBS

**SHEARWALL ASSEMBLY SPECIFICATION**

P1 - 1-SIDE 7/16" OSB  
FASTENED W/ 8D NAILS AT 6"O.C. PANEL EDGES & 12"O.C. PANEL FIELD - EDGES BLOCKED  
**#DIV/0!**

**OVERTURNING EVALUATION:**

RESISTIVE DL  PLF OVERTURNING MOMENT  K-FT HOLD DOWN DESIGN LOAD  LBS  
DL AT ENDS OF WALL  LBS RESISTIVE MOMENT  K-FT HOLDOWN CAPACITY  LBS

**HOLD-DOWN SPECIFICATION**

**NO HOLDOWN REQUIRED**

ARCH INNOVATIONS  
PRATT PLAT - LOT 2

MERCER ISLAND, WA

SHEAR WALL CALCULATIONS - SEISMIC DESIGN

*REVIEWED BY: NJM*

*FEBRUARY 22, 2021*

*PARAMETERS:*

*SINGLE FAMILY HOME*

*DESIGN WIND SPEED: 100 MPH*

*WIND EXPOSURE CATEGORY: B*

*SEISMIC DESIGN CATEGORY: D*

*CODE & DESIGN STANDARD: 2018 IBC CH. 1609, ASCE 7-16 CH. 26-30*



**MULHERN+KULP**  
RESIDENTIAL STRUCTURAL ENGINEERING

**SEISMIC CALCULATION - ASCE 7-16**

**SEISMIC DESIGN CATEGORY:**

USER INPUTS:

SITE CLASS	C
SPECTRAL RESPONSE ACCELERATION 0.2 SEC, <b>S<sub>B</sub></b>	1.460
SPECTRAL RESPONSE ACCELERATION 1.0 SEC, <b>S<sub>1</sub></b>	0.560
OCCUPANCY CATEGORY	II

VARIABLES:

SITE COEFFICIENT, F <sub>A</sub>	1.20
SITE COEFFICIENT, F <sub>V</sub>	1.44

CALCULATED VALUES:

MAXIMUM SPECTRAL RESPONSE ACCELERATION, <b>S<sub>M8</sub></b>	1.752
MAXIMUM SPECTRAL RESPONSE ACCELERATION, <b>S<sub>M1</sub></b>	0.806
DESIGN SPECTRAL RESPONSE ACCELERATION, <b>S<sub>D8</sub></b>	1.168
DESIGN SPECTRAL RESPONSE ACCELERATION, <b>S<sub>D1</sub></b>	0.538
SEISMIC DESIGN CATEGORY (SHORT TERM)	D
SEISMIC DESIGN CATEGORY (1.0 SECOND TERM)	D

**BUILDING PERIOD DETERMINATION:**

USER INPUTS:

BUILDING PERIOD COEFFICIENT, C <sub>T</sub>	0.020
LONG-PERIOD TRANS PERIOD, T <sub>L</sub> (SEC)	6
HT. ABV BASE TO HIGHEST LEVEL, h <sub>N</sub>	19

CALCULATED VALUES:

APPROXIMATE FUNDAMENTAL PERIOD, T <sub>A</sub>	0.183
T <sub>0</sub>	0.092
T <sub>B</sub>	0.460
SPECTRAL RESPONSE ACC., S <sub>A</sub> (G)	1.168

**SITE CLASS ASSUMPTION**

**D** PER ASCE 7-16 SECTION 11.4.3 THE SITE CLASS MAY BE ASSUMED TO BE D

**EQUIVALENT LATERAL FORCE PROCEDURE**

DEAD LOAD CALCULATION:

LEVEL	STORY HT. (FT.)	AREA (FT <sup>2</sup> )	DEAD LOAD (PSF)	DL OF EXT WALL TRIB. TO LEVEL (KIPS)	TOTAL LEVEL DL
1	10.1	2844	15	15.0	58 K
2	9.0	2252	17	6.8	45 K
3	0.0	0	0	0.0	0 K
4	0.0	0	0	0.0	0 K
5	0.0	0	0	0.0	0 K
6	0.0	0	0	0.0	0 K
7	0.0	0	0	0.0	0 K
8	0.0	0	0	0.0	0 K
9	0.0	0	0	0.0	0 K
10	0.0	0	0	0.0	0 K
11	0.0	0	0	0.0	0 K
12	0.0	0	0	0.0	0 K
13	0.0	0	0	0.0	0 K
14	0.0	0	0	0.0	0 K
15	0.0	0	0	0.0	0 K
16	0.0	0	0	0.0	0 K
17	0.0	0	0	0.0	0 K
18	0.0	0	0	0.0	0 K
19	0.0	0	0	0.0	0 K
20	0.0	0	0	0.0	0 K

**TOTAL DEAD LOAD OF STRUCTURE** 103 KIPS

SEISMIC RESPONSE COEFFICIENT:

	TRANSVERSE	LONGITUDINAL
RESPONSE MODIFICATION FACTOR, R	6.5	6.5
OCCUPANCY IMPORTANCE FACTOR, I <sub>e</sub>	1.00	1.00
SEISMIC RESPONSE COEFFICIENT, C <sub>s</sub>	0.180	0.180

BASE SHEARS:

**ULTIMATE LOADS**

x 0.7 =

**ALLOWABLE LOADS**

TRANSVERSE	LONGITUDINAL	TRANSVERSE	LONGITUDINAL
18 K	18 K	12.9 K	12.9 K

STORY SHEAR CALCULATION:

DISTRIBUTION EXPONENT, **1.00**

**ULTIMATE LOADS**

x 0.7 =

**ALLOWABLE LOADS**

LEVEL	VERT. DIST. FACTOR, C <sub>vk</sub>	TRANSVERSE		LONGITUDINAL		TRANSVERSE		LONGITUDINAL	
		STORY SHEAR, F <sub>v</sub>	STORY SHEAR, F <sub>v</sub>	STORY SHEAR, F <sub>v</sub>	STORY SHEAR, F <sub>v</sub>	STORY SHEAR, F <sub>v</sub>	STORY SHEAR, F <sub>v</sub>		
1	0.403	7.4 K	7.4 K	5.2 K	12.9 K	5.2 K	12.9 K		
2	0.597	11.0 K	11.0 K	7.7 K	7.7 K	7.7 K	7.7 K		
3	0.000	0.0 K	0.0 K	0.0 K	0.0 K	0.0 K	0.0 K		
4	0.000	0.0 K	0.0 K	0.0 K	0.0 K	0.0 K	0.0 K		
5	0.00	0.0 K	0.0 K	0.0 K	0.0 K	0.0 K	0.0 K		
6	0.00	0.0 K	0.0 K	0.0 K	0.0 K	0.0 K	0.0 K		
7	0.00	0.0 K	0.0 K	0.0 K	0.0 K	0.0 K	0.0 K		
8	0.00	0.0 K	0.0 K	0.0 K	0.0 K	0.0 K	0.0 K		
9	0.00	0.0 K	0.0 K	0.0 K	0.0 K	0.0 K	0.0 K		
10	0.00	0.0 K	0.0 K	0.0 K	0.0 K	0.0 K	0.0 K		
11	0.00	0.0 K	0.0 K	0.0 K	0.0 K	0.0 K	0.0 K		
12	0.00	0.0 K	0.0 K	0.0 K	0.0 K	0.0 K	0.0 K		
13	0.00	0.0 K	0.0 K	0.0 K	0.0 K	0.0 K	0.0 K		
14	0.00	0.0 K	0.0 K	0.0 K	0.0 K	0.0 K	0.0 K		
15	0.00	0.0 K	0.0 K	0.0 K	0.0 K	0.0 K	0.0 K		
16	0.00	0.0 K	0.0 K	0.0 K	0.0 K	0.0 K	0.0 K		
17	0.00	0.0 K	0.0 K	0.0 K	0.0 K	0.0 K	0.0 K		
18	0.00	0.0 K	0.0 K	0.0 K	0.0 K	0.0 K	0.0 K		
19	0.00	0.0 K	0.0 K	0.0 K	0.0 K	0.0 K	0.0 K		
20	0.00	0.0 K	0.0 K	0.0 K	0.0 K	0.0 K	0.0 K		

**GENERAL PLAN NOTES**

1. SEE SHEET A-1 FOR ALL GENERAL NOTES AND REQUIREMENTS.
2. ENERGY AND AIR QUALITY INFORMATION SEE DIV. II SHEET A-1
3. SEE BUILDING ELEVATION FOR WINDOW OPERATION SEE DIV. 8 SHEET A-1
4. SEE TYP. MATERIALS LIST ON SECTION SHEET
5. SEE SHEET A-1 FOR ALL NOTES AND REQUIREMENTS CONCERNING MECHANICAL, PLUMBING, AND ELECTRICAL.

**FLOOR PLAN KEY NOTES**

- P-1 OCCUPANCY SEPARATION:  
APPLY (1) LAYER OF 1/2" GWB. TO GARAGE SIDE OF RESIDENCE, ATTIC SPACES, AND TO ALL BEAMS AND POSTS SUPPORTING A FLOOR-CEILING ASSEMBLY. APPLY (1) LAYER OF 1/2" TYPE "X" GWB. TO GARAGE CEILING UNDER HABITABLE ROOMS. DUCTS THROUGH WALL OR CEILING COMMON TO HOUSE SHALL HAVE MINIMUM 76 GAUGE STEEL. SEE DIV. 01007.6.A SHEET A-1
- P-2 1/4" MIN SELF CLOSING SOLID WOOD CORE, HONEY-COMB CORE STEEL, OR 20-MINUTE FIRE RATED DOOR. SEE DIV. 01007.6.B SHEET A-1
- P-3 STAIR ASSEMBLY NOTES: PER IRC, SECTION R301.5 AND DETAIL 1127.  
A. HEADROOM MIN 6'-8", WIDTH MIN 3'-0".  
B. TREADS 10" MIN DEPTH AND MIN WIDTH OF 36" ABOVE HANDRAIL HEIGHT, RISERS 7 1/4" MAX HT. TREAD NOSING TO BE MINIMUM 3/4" AND A MAXIMUM OF 1/4" ON STAIRS WITH SOLID RISERS.  
C. HANDRAIL MIN 34" TO MAX 38" ABOVE TREAD NOSING. HANDRAIL TYPE I CIRCULAR TO HAVE 1 1/4" MIN TO 2" MAX CROSS SECTION DIMENSION AND 1/2" MIN CLEAR FROM WALL, RETURN RAIL ENDS. HANDRAILS SHALL BE STRONG ENOUGH TO RESIST A 200 LBS POINT LOAD IN ANY DIRECTION PER IRC, TABLE R301.5 D. INSTALL FIRE BLOCKING BETWEEN STRINGERS AT THE TOP AND BOTTOM OF EACH RUN PER IRC, SECTION R302.1  
E. COVER USABLE SPACE UNDER STAIR W 1/2" GWB. PER IRC, SECTION R302.1  
F. INTERMEDIATE BALUSTERS SHALL BE SPACED W LESS THAN 4" BETWEEN BALUSTERS.  
G. PROVIDE STAIRWAY ILLUMINATION PER IRC, SECTION R303.6. SEE DIV. 01007.1 SHEET A-1
- P-4 SAFETY GLAZING PER IRC, SECTION R308  
A. WINDOWS WITHIN 18" OF FLOOR  
B. WINDOWS WITHIN 24" ARC OF DOORS  
C. WINDOWS AT TUBS AND SHOWERS  
D. GLAZING IN DOORS  
E. LESS THAN 60" HORIZ FROM THE BOT. STAIR TREAD NOSING, 1 BOT. EDGE OF GLAZING IS LESS THAN 36" ABV. LANDING WALKING SURFACE. SEE DIV. 01007.1 SHEET A-1
- P-5 EGRESS WINDOW PER IRC, SECTION R310 SEE DIV. 01007.1 SHEET A-1
- P-6 IGNITERS FOR GAS FIRED APPLIANCES IN GARAGE TO BE 18" MIN. ABOVE TOP OF SLAB. SEE DIV. 15 SHEET A-1
- P-7 COVER WALLS ADJACENT TO TUBS AND SHOWERS WITH NON-ABSORBENT MATERIAL TO 7' ABOVE DRAIN INLETS, PER IRC, SECTION 3012. SEE DIV. 01007.1 SHEET A-1
- P-8 (2) LAYERS OF FLOOR SHEATHING OVER FRAMING.
- P-9 7/4" MAX RISER WITH 10" MIN RUN, IF MORE THAN (3) RISERS, HANDRAIL REQUIRED PER IRC, SECTION R301.5. SEE DIV. 01007.1 SHEET A-1
- P-10 18"x24" CRAWL SPACE ACCESS, INSULATE AND WEATHER STRIP. SEE DIV. 01007.1 SHEET A-1
- P-11 22"x36" ATTIC SPACE ACCESS W 30" HEAD CLEARANCE, INSULATE AND WEATHER STRIP. SEE DIV. 01007.2 SHEET A-1
- P-12 FLOOR MATERIAL BREAK LINE
- P-13 WALL LINE ABOVE
- P-14 WALL LINE BELOW
- P-15 FIREPLACE ASSEMBLY NOTES:  
A. DIRECT VENT GAS FIREPLACES, MUST BE LISTED, LABELED INSTALLED PER PFG. SPECIFICATIONS, SHALL CONFORM TO IRC REQUIREMENTS. SEE DIV. 01007.2 SHEET A-1  
B. ZERO CLEARANCE FIREPLACES SHALL CONFORM TO IRC REQUIREMENTS. SEE DIV. 01007.2 SHEET A-1  
C. HEARTH SHALL CONFORM TO IRC REQUIREMENT SEE DIV. 01007.2  
D. FIREBLOCK OPENINGS AROUND PENETRATIONS = EACH FLOOR PER IRC, SECTION R303.3.  
E. FIREPLACE MUST COMPLY WITH UL 117 TESTING
- P-16 SEE SITE PLAN FOR EXTENT OF WALKS & DRIVEWAYS
- P-17 3" DIAMETER STEEL POST
- P-18 36" GUARDRAIL PER IRC, SECTION R301 & TABLE R301.5 CONTRACTOR TO VERIFY TO INSPECTOR THAT ALL GUARDS & RAILINGS ARE CAPABLE OF RESISTING 200 LBS LOAD ON TOP RAIL ACTING IN ANY DIRECTION
- P-19 1" VENT FOR MECHANICAL, 1" CLEARANCE ALL SIDES PER IRC, SECTION R302.1 SEE DIV. 15 SHEET A-1
- P-20 PLANT SHELF
- P-21 UPPER AND LOWER LINEN CABINETS
- P-22 SOFFIT AREA
- P-23 INTEGRATED MAKE UP AIR
- P-24 2x6 STUDS W R-21 INSULATION MIN.

WIND DESIGN  
SEISMIC DESIGN

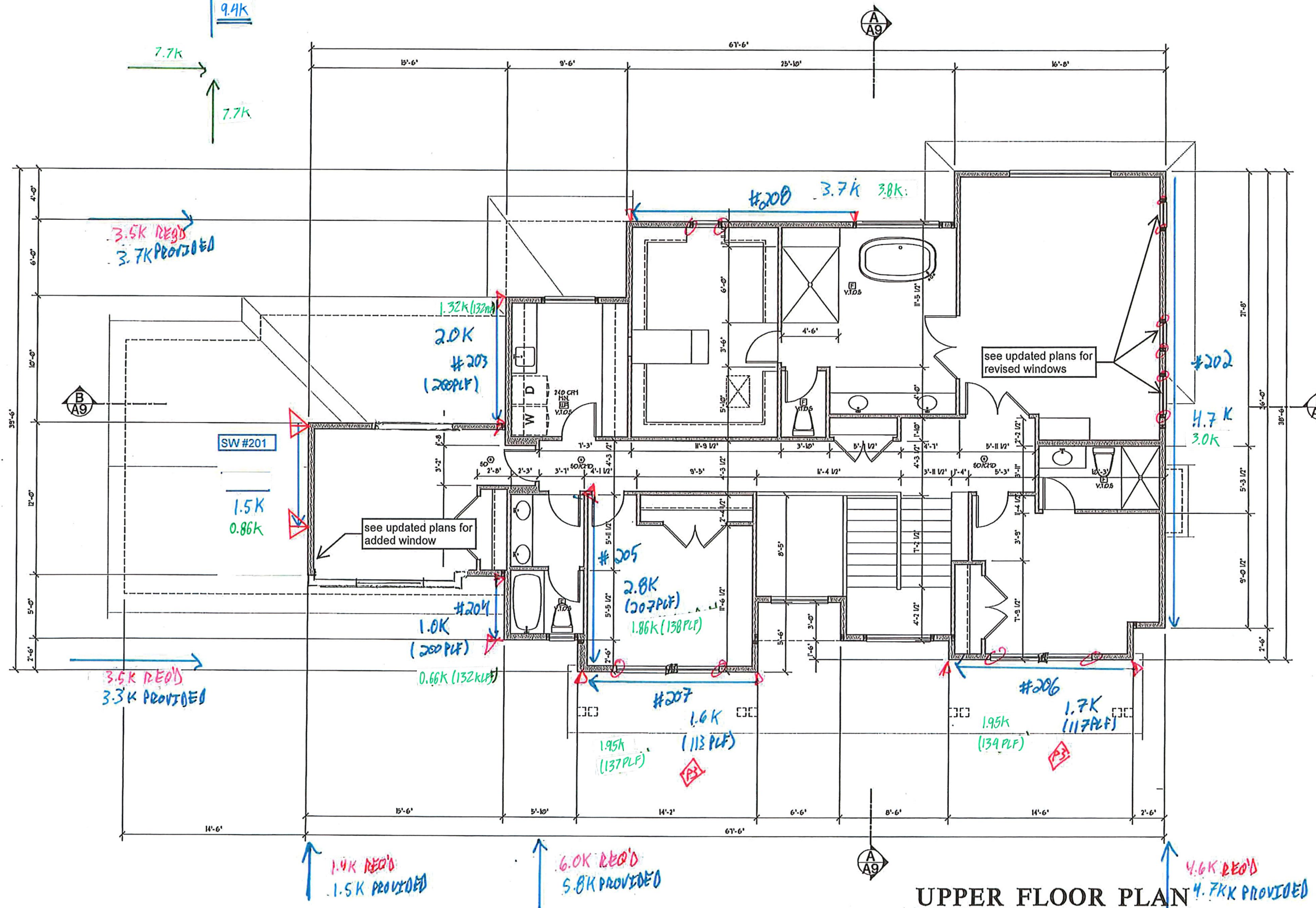
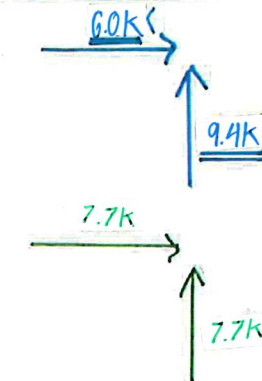

**UPPER FLOOR PLAN** 4.7K PROVIDED

Scale 1/4"=1'-0"

Date	By	Description
09/27/18	SM	PRELIMINARY DESIGN
10/02/18	SM	ELEVATION DESIGN
10/22/18	SM	DESIGN REVISIONS
12/17/18	REY	KITCHEN REVISIONS
12/20	SM	ELEVATION DESIGN

**Pratt Plat**  
7233 80th Ave SE  
Mercer Island, WA 98040

**ARCHITECTURAL INNOVATIONS, P.S.**  
Forward Thinking Design Solutions For Your Environment  
14311 SE 16th St  
Bellevue, WA 98007  
1-800-888-4517  
www.archinnovationsps.com

TITLE	
JOB NO.:	1903705
STARTING NO.:	1903705

SHEET  
**A5**

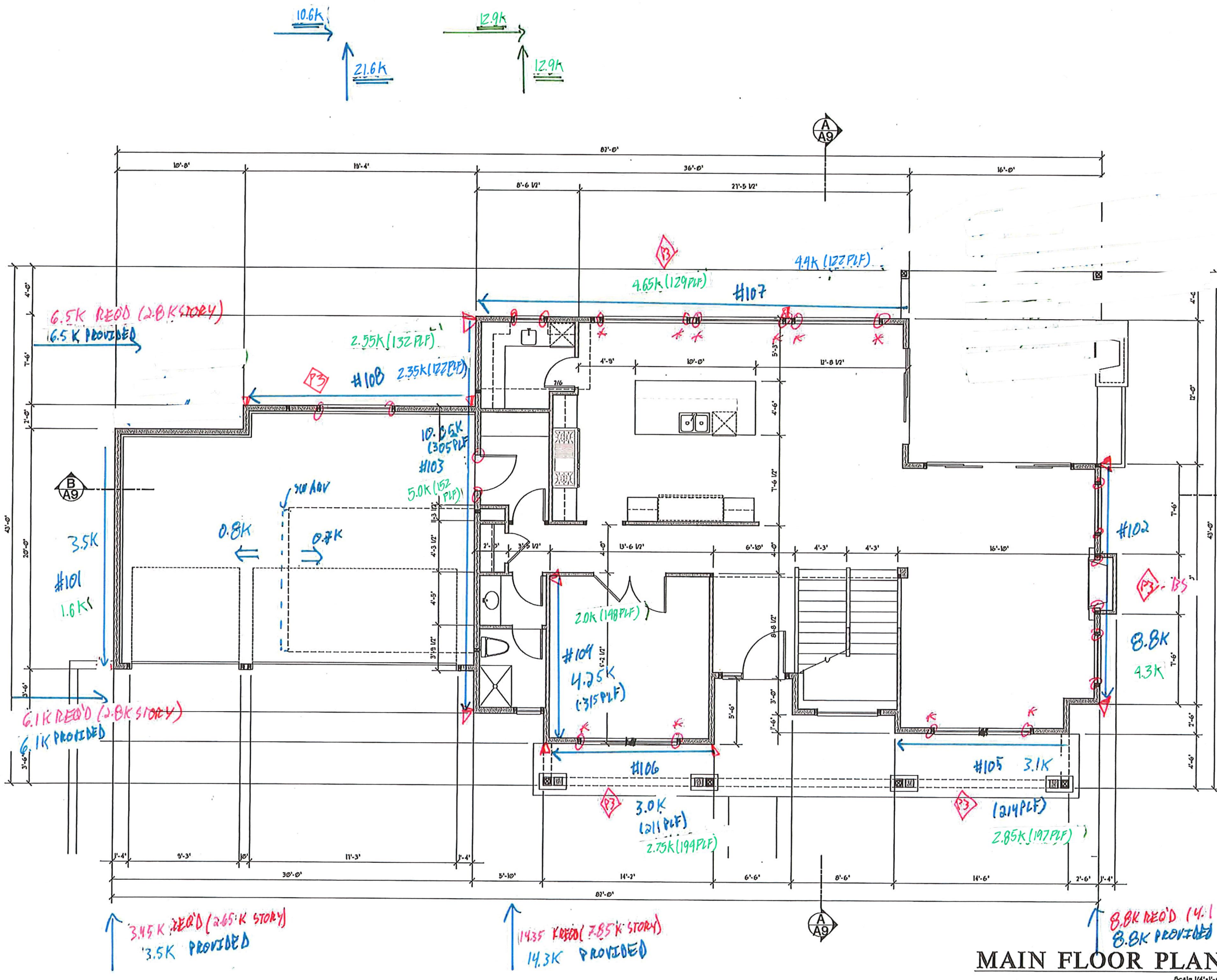

**GENERAL PLAN NOTES**

1. SEE SHEET A-1 FOR ALL GENERAL NOTES AND REQUIREMENTS.
2. ENERGY AND AIR QUALITY INFORMATION SEE DIV. 11 SHEET A-1
3. SEE BUILDING ELEVATION FOR WINDOW OPERATION SEE DIV. 8 SHEET A-1
4. SEE TYP. MATERIALS LIST ON SECTION SHEET
5. SEE SHEET A-1 FOR ALL NOTES AND REQUIREMENTS CONCERNING MECHANICAL, PLUMBING, AND ELECTRICAL.

**FLOOR PLAN KEY NOTES**

- P-1** OCCUPANCY SEPARATION. APPLY (1) LAYER OF 1/2" GIBB. TO GARAGE SIDE OF RESIDENCE, ATTIC SPACES, AND TO ALL BEAMS AND POSTS SUPPORTING A FLOOR-CEILING ASSEMBLY. APPLY (1) LAYER OF 1/2" TYPE "X" GIBB. TO GARAGE CEILING WHEN UNDER HABITABLE ROOFS. DUCTS THROUGH WALL OR CEILING COFFIN TO HOUSE SHALL HAVE MINIMUM 76 GAUGE STEEL. SEE DIV. 010216.A. SHEET A-1.
- P-2** 1/4" MIN. SELF CLOSING SOLID WOOD CORE, HONEY-COMB CORE STEEL, OR 20-MINUTE FIRE RATED DOOR. SEE DIV. 010216.B. SHEET A-1.
- P-3** STAIR ASSEMBLY NOTES: PER IRC, SECTION R301.5 AND DETAIL 17/D2.
  - A. HEADROOM MIN. 6'-8", WIDTH MIN. 3'-0".
  - B. TREADS 10" MIN. DEPTH AND MIN. WIDTH OF 36" ABOVE HANDRAIL. HEIGHT, RISERS 7/8" MAX. HT. TREAD NOSING TO BE MINIMUM 3/4" AND A MAXIMUM OF 1/4" ON STAIRS WITH SOLID RISERS.
  - C. HANDRAIL MIN. 34" TO MAX 38" ABOVE TREAD NOSING. HANDRAIL TYPE I CIRCULAR TO HAVE 1 1/2" MIN. TO 2" MAX. CROSS SECTION DIMENSION AND 1 1/2" MIN. CLEAR FROM WALL. RETURN RAIL ENDS. HANDRAILS SHALL BE STRONG ENOUGH TO RESIST A 200 LBS. POINT LOAD IN ANY DIRECTION PER IRC, TABLE R301.5.
  - D. INSTALL FIRE BLOCKS BETWEEN STRINGERS AT THE TOP AND BOTTOM OF EACH RUN PER IRC, SECTION R302.1.
  - E. COVER USABLE SPACE UNDER STAIR W/ 1/2" GIBB. PER IRC, SECTION R302.1.
  - F. INTERMEDIATE BALUSTERS SHALL BE SPACED W/ LESS THAN 4" BETWEEN BALUSTERS.
  - G. PROVIDE STAIRWAY ILLUMINATION PER IRC, SECTION R303.6. SEE DIV. 09001 SHEET A-1.
- P-4** SAFETY GLAZING PER IRC, SECTION R308.
  - A. WINDOWS WITHIN 18" OF FLOOR.
  - B. WINDOWS WITHIN A 24" ARC OF DOORS.
  - C. WINDOWS AT TUBS AND SHOWERS.
  - D. GLAZING IN DOORS.
  - E. LESS THAN 60" HORIZ. FROM THE BOT. STAIR TREAD NOSING, 1" BOT. EDGE OF GLAZING IS LESS THAN 36" ABV. LANDING/WALKING SURFACE. SEE DIV. 08002 SHEET A-1.
- P-5** EGRESS WINDOW PER IRC, SECTION R310. SEE DIV. 08000 SHEET A-1.
- P-6** IGNITERS FOR GAS FIRED APPLIANCES IN GARAGE TO BE 1/2" MIN. ABOVE TOP OF SLAB. SEE DIV. 15 SHEET A-1.
- P-7** COVER WALLS ADJACENT TO TUBS AND SHOWERS WITH NON-ABSORBENT MATERIAL TO 1/2" ABOVE DRAIN INLETS, PER IRC, SECTION 3012. SEE DIV. 09000 SHEET A-1.
- P-8** (2) LAYERS OF FLOOR SHEATHING OVER FRAMING.
- P-9** 1/4" MAX. RISER WITH 10" MIN. RUN IF MORE THAN (3) RISERS. HANDRAIL REQUIRED PER IRC, SECTION R301.5. SEE DIV. 010211 SHEET A-1.
- P-10** 10"x24" CRAWL SPACE ACCESS. INSULATE AND WEATHER STRIP. SEE DIV. 010211 SHEET A-1.
- P-11** 22"x30" ATTIC SPACE ACCESS W/ 30" HEAD CLEARANCE. INSULATE AND WEATHER STRIP. SEE DIV. 010212 SHEET A-1.
- P-12** FLOOR MATERIAL BREAK LINE
- P-13** WALL LINE ABOVE
- P-14** WALL LINE BELOW
- P-15** FIREPLACE ASSEMBLY NOTES:
  - A. DIRECT VENT GAS FIREPLACES, MUST BE LISTED, LABELED, INSTALLED PER MFG. SPECIFICATIONS, SHALL CONFORM TO IRC REQUIREMENTS. SEE DIV. 010211 SHEET A-1.
  - B. ZERO CLEARANCE FIREPLACES SHALL CONFORM TO IRC REQUIREMENTS. SEE DIV. 010211 SHEET A-1.
  - C. HEARTH SHALL CONFORM TO IRC REQUIREMENT SEE DIV. 010211 SHEET A-1.
  - D. FIREBLOCK OPENINGS AROUND PENETRATIONS
  - E. EACH FLOOR PER IRC, SECTION R303.5.
  - F. FIREPLACE MUST COMPLY WITH UL 121 TESTING
- P-16** SEE SITE PLAN FOR EXTENT OF WALKS & DRIVEWAYS
- P-17** 3" DIAMETER STEEL POST
- P-18** 36" GUARDRAIL PER IRC, SECTION R301.1 TABLE R301.5 CONTRACTOR TO VERIFY TO INSPECTOR THAT ALL GUARDS & RAILINGS ARE CAPABLE OF RESISTING 200 LBS. LOAD ON TOP RAIL ACTING IN ANY DIRECTION.
- P-19** 1" VENT FOR MECHANICAL. 1" CLEARANCE ALL SIDES PER IRC, SECTION R302.1. SEE DIV. 15 SHEET A-1
- P-20** PLANT SHELF
- P-21** UPPER AND LOWER LINEN CABINETS
- P-22** SOFFIT AREA
- P-23** INTEGRATED MAKE UP AIR
- P-24** 2x6 STUDS W/ R-21 INSULATION MIN.

Date	By	Description
02/27/20	SA	PRELIMINARY DESIGN
03/27/20	SA	ELEVATION DESIGN
07/27/20	SA	DESIGN REVISIONS
07/27/20	BSY	KITCHEN REVISIONS
10/27	SA	ELEVATION DESIGN

**Pratt Plat**  
 Lot 4  
 7233 80th Ave SE  
 Mercer Island, WA 98040

THIS DRAWING IS © COPYRIGHTED ARCHITECTURAL INNOVATIONS, P.S. ALL RIGHTS RESERVED

**ARCHITECTURAL INNOVATIONS, P.S.**  
 Forward Thinking Design Solutions For Your Environment  
 14311 SE 16th St  
 Bellevue, WA 98007  
 1-800-888-4517  
 www.architecturalinnovations.com

**SQUARE FOOTAGE**

MAIN FLOOR	1558 SF
UPPER FLOOR	1791 SF
LOWER FLOOR	1278 SF
<b>TOTAL</b>	<b>4622 SF</b>
GARAGE	639 SF
PORCH	224 SF
PATIO	259 SF

**MAIN FLOOR PLAN**

Scale 1/4"=1'-0"

TITLE
JOB NO. 1: 1903103
STARTING NO. 1: 1903103
SHEET
<b>A3</b>

**GENERAL PLAN NOTES**

- SEE SHEET A-1 FOR ALL GENERAL NOTES AND REQUIREMENTS.
- ENERGY AND AIR QUALITY INFORMATION SEE DIV. 11 SHEET A-1
- SEE BUILDING ELEVATION FOR WINDOW OPERATION SEE DIV. 8 SHEET A-1
- SEE TYP. MATERIALS LIST ON SECTION SHEET
- SEE SHEET A-1 FOR ALL NOTES AND REQUIREMENTS CONCERNING MECHANICAL, PLUMBING, AND ELECTRICAL.

**FLOOR PLAN KEY NOTES**

- P-1 OCCUPANCY SEPARATION: APPLY (1) LAYER OF 1/2" G.W.B. TO GARAGE SIDE OF RESIDENCE, ATTIC SPACES, AND TO ALL BEAMS AND POSTS SUPPORTING A FLOOR-CEILING ASSEMBLY. APPLY (2) LAYER OF 1/2" TYPE "X" G.W.B. TO GARAGE CEILING WHEN UNDER HABITABLE ROOMS. DUCTS THROUGH WALL OR CEILING COMMON TO HOUSE SHALL HAVE MINIMUM 26 GAUGE STEEL. SEE DIV. 01007.6.A SHEET A-1
- P-2 1 1/2" MIN. SELF-CLOSING SOLID WOOD CORE, HONEY-COMB CORE STEEL, OR 20-MINUTE FIRE RATED DOOR. SEE DIV. 01007.6.B SHEET A-1
- P-3 STAIR ASSEMBLY NOTES: PER IRC, SECTION R301.5 AND DETAIL 1027.
  - A. HEADROOM MIN. 6'-8", WIDTH MIN. 3'-0".
  - B. TREADS 10" MIN. DEPTH AND MIN. WIDTH OF 36" ABOVE HANDRAIL HEIGHT, RISERS 7 1/4" MAX. HT. TREAD NOSING TO BE MINIMUM 3/4" AND A MAXIMUM OF 1 1/4" ON STAIRS WITH SOLID RISERS.
  - C. HANDRAIL MIN. 34" TO MAX. 38" ABOVE TREAD NOSING. HANDRAIL TYPE I CIRCULAR TO HAVE 1 1/4" MIN. TO 2" MAX. CROSS SECTION DIMENSION AND 1 1/2" MIN. CLEAR FROM WALL, RETURN RAIL ENDS. HANDRAILS SHALL BE STRONG ENOUGH TO RESIST A 200 LBS POINT LOAD IN ANY DIRECTION PER IRC, TABLE R301.5 D.
  - D. INSTALL FIRE BLOCKING BETWEEN STRINGERS AT THE TOP AND BOTTOM OF EACH RUN PER IRC, SECTION R307.1
  - E. COVER USABLE SPACE UNDER STAIR W 1/2" G.W.B. PER IRC, SECTION R307.1
  - F. INTERMEDIATE BALUSTERS SHALL BE SPACED W/ LESS THAN 4" BETWEEN BALUSTERS.
  - G. PROVIDE STAIRWAY ILLUMINATION PER IRC, SECTION R303.6. SEE DIV. 01007.1 SHEET A-1
- P-4 SAFETY GLAZING PER IRC, SECTION R308
  - A. WINDOWS WITHIN 18" OF FLOOR
  - B. WINDOWS WITHIN A 74" ARC OF DOORS
  - C. WINDOWS AT TUBS AND SHOWERS
  - D. GLAZING IN DOORS
  - E. LESS THAN 60" HORIZ. FROM THE BOT. STAIR TREAD NOSING, 1 BOT. EDGE OF GLAZING IS LESS THAN 36" ABV. LANDING/WALKING SURFACE. SEE DIV. 01007.1 SHEET A-1
- P-5 EGRESS WINDOW PER IRC, SECTION R310 SEE DIV. 01007.0 SHEET A-1
- P-6 IGNITERS FOR GAS FIRED APPLIANCES IN GARAGE TO BE 18" MIN. ABOVE TOP OF SLAB. SEE DIV. 10 SHEET A-1
- P-7 COVER WALLS ADJACENT TO TUBS AND SHOWERS WITH NON-ABSORBENT MATERIAL TO 1' ABOVE DRAIN INLETS, PER IRC, SECTION 3012. SEE DIV. 09150 SHEET A-1
- P-8 (2) LAYERS OF FLOOR SHEATHING OVER FRAMING.
- P-9 7/8" MAX. RISER WITH 10" MIN. RUN. IF MORE THAN (3) RISERS, HANDRAIL REQUIRED PER IRC, SECTION R301.5. SEE DIV. 01007.1 SHEET A-1
- P-10 18"x24" CRAIL SPACE ACCESS, INSULATE AND WEATHER STRIP. SEE DIV. 01007.1 SHEET A-1
- P-11 22"x30" ATTIC SPACE ACCESS W/ 30" HEAD CLEARANCE, INSULATE AND WEATHER STRIP. SEE DIV. 01007.2 SHEET A-1
- P-12 FLOOR MATERIAL BREAK LINE
- P-13 WALL LINE ABOVE
- P-14 WALL LINE BELOW
- P-15 FIREPLACE ASSEMBLY NOTES:
  - A. DIRECT VENT GAS FIREPLACES, MUST BE LISTED, LABELED (INSTALLED PER IFG. SPECIFICATIONS, SHALL CONFORM TO IRC REQUIREMENTS. SEE DIV. 01007.1 SHEET A-1
  - B. ZERO CLEARANCE FIREPLACES SHALL CONFORM TO IRC, REQUIREMENTS. SEE DIV. 01007.1 SHEET A-1
  - C. HEARTH SHALL CONFORM TO IRC REQUIREMENT SEE DIV. 01007.1
  - D. FIREBLOCK OPENINGS AROUND PENETRATIONS @ EACH FLOOR PER IRC, SECTION R1003.3
  - E. FIREPLACE MUST COMPLY WITH UL 171 TESTING
- P-16 SEE SITE PLAN FOR EXTENT OF WALKS & DRIVEWAYS
- P-17 3" DIAMETER STEEL POST
- P-18 36" GUARDRAIL PER IRC, SECTION R302 & TABLE R302.5 CONTRACTOR TO VERIFY TO INSPECTOR THAT ALL GUARDS & RAILINGS ARE CAPABLE OF RESISTING 200 LBS LOAD ON TOP RAIL ACTING IN ANY DIRECTION
- P-19 18" VENT FOR MECHANICAL, 1" CLEARANCE ALL SIDES PER IRC, SECTION R302.1 SEE DIV. 15 SHEET A-1
- P-20 PLANT SHELVE
- P-21 UPPER AND LOWER LINEN CABINETS
- P-22 SOFFIT AREA
- P-23 INTEGRATED MAKE UP AIR
- P-24 2x6 STUDS W/ R-21 INSULATION MIN.

Date	By	Description
	SA	PRELIMINARY DESIGN
	SA	FOUNDATION DESIGN
	SA	DESIGN REVISION
	SA	DESIGN REVISION
	SA	DESIGN REVISION
	SA	ELEMENT DESIGN

**Pratt Plat**  
 Lot 4  
 7233 80th Ave SE  
 Mercer Island, WA 98040  
 THIS DRAWING IS © COPYRIGHTED ARCHITECTURAL INNOVATIONS, P.S. ALL RIGHTS RESERVED

**ARCHITECTURAL INNOVATIONS, P.S.**  
 Forward Thinking Design Solutions For Your Environment  
 14311 SE 16th St.  
 Bellevue, WA 98007  
 1-800-888-4517  
 www.archinnovations.com

TITLE
LOWER FLOOR PLAN
JOB NO.: 1107103
STARTING NO.: 1107103
SHEET
<b>A2.1</b>

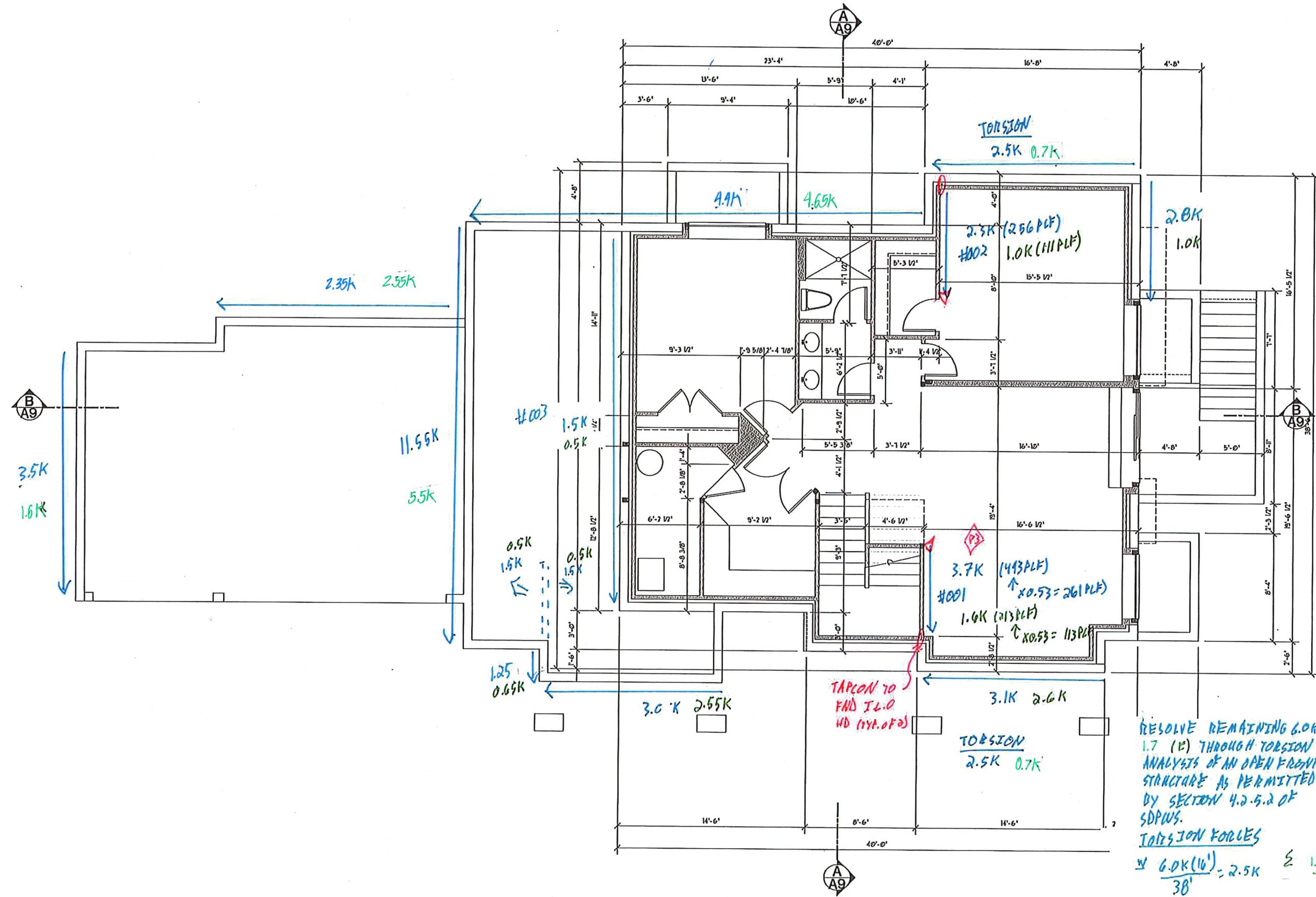

RESOLVE REMAINING 6.0K (W/ 1.7 (K) THROUGH TORSION ANALYSIS OF AN OPEN FRONT STRUCTURE AS PERMITTED BY SECTION 4.2.5.2 OF SDPIWS.  
 TORSION FORCES  
 $\frac{6.0K(16')}{38'} = 2.5K \leq \frac{1.7 K(16')}{38'} = 0.7K$

**LOWER FLOOR PLAN**  
 Scale: 1/4"=1'-0"





**SHEARWALL DESIGN SUMMARY**

**SHEARWALL 201:** 2ND - SIDE EXT. WALL @ BED 4

**SHEARWALL PROPERTIES:**

WALL HEIGHT, H  FT.      MAX WALL OPENING HT, H<sub>c</sub>  FT.  
WALL LENGTH, L  FT.      QUALIFYING WALL LENGTH, L  FT.      SHEARWALL ASSEMBLY

**CAPACITY EVALUATION:**

TOTAL SHEAR LOAD ON WALL  LBS < ALLOWABLE SHEARWALL CAPACITY  LBS

**SHEARWALL ASSEMBLY SPECIFICATION**

P1 - 1-SIDE 7/16" OSB  
FASTENED W/ 8D NAILS AT 6"O.C. PANEL EDGES & 12"O.C. PANEL FIELD - EDGES BLOCKED  
**ADEQUATE**

**OVERTURNING EVALUATION:**

RESISTIVE DL  PLF      OVERTURNING MOMENT  K-FT      HOLD DOWN DESIGN LOAD  LBS  
DL AT ENDS OF WALL  LBS      RESISTIVE MOMENT  K-FT      HOLDDOWN CAPACITY  LBS

**HOLD-DOWN SPECIFICATION**

**SIMPSON CS 16 STRAP TIE (14" END LENGTH)**

**SHEARWALL 202:** 2ND - SIDE EXT. WALL @ MASTER BED TO BED 2

**SHEARWALL PROPERTIES:**

WALL HEIGHT, H  FT.      MAX WALL OPENING HT, H<sub>c</sub>  FT.  
WALL LENGTH, L  FT.      QUALIFYING WALL LENGTH, L  FT.      SHEARWALL ASSEMBLY

**CAPACITY EVALUATION:**

TOTAL SHEAR LOAD ON WALL  LBS < ALLOWABLE SHEARWALL CAPACITY  LBS

**SHEARWALL ASSEMBLY SPECIFICATION**

P1 - 1-SIDE 7/16" OSB  
FASTENED W/ 8D NAILS AT 6"O.C. PANEL EDGES & 12"O.C. PANEL FIELD - EDGES BLOCKED  
**ADEQUATE**

**OVERTURNING EVALUATION:**

RESISTIVE DL  PLF      OVERTURNING MOMENT  K-FT      HOLD DOWN DESIGN LOAD  LBS  
DL AT ENDS OF WALL  LBS      RESISTIVE MOMENT  K-FT      HOLDDOWN CAPACITY  LBS

**HOLD-DOWN SPECIFICATION**

**NO HOLDDOWN REQUIRED**



**SHEARWALL DESIGN SUMMARY**

**SHEARWALL 203:** 2ND - SIDE EXT. WALL @ UTILITY

**SHEARWALL PROPERTIES:**

WALL HEIGHT, H  FT.      MAX WALL OPENING HT, H<sub>c</sub>  FT.  
WALL LENGTH, L  FT.      QUALIFYING WALL LENGTH, L  FT.      SHEARWALL ASSEMBLY

**CAPACITY EVALUATION:**

TOTAL SHEAR LOAD ON WALL  LBS < ALLOWABLE SHEARWALL CAPACITY  LBS

**SHEARWALL ASSEMBLY SPECIFICATION**

P1 - 1-SIDE 7/16" OSB  
FASTENED W/ 8D NAILS AT 6"D.C. PANEL EDGES & 12"D.C. PANEL FIELD - EDGES BLOCKED  
**ADEQUATE**

**OVERTURNING EVALUATION:**

RESISTIVE DL  PLF      OVERTURNING MOMENT  K-FT      UPLIFT CONNECTOR DESIGN LOAD  LBS  
DL AT ENDS OF WALL  LBS      RESISTIVE MOMENT  K-FT      HOLDOWN CAPACITY  LBS

**HOLD-DOWN SPECIFICATION**

**SIMPSON GS 16 STRAP TIE (14" END LENGTH)**

**SHEARWALL 204:** 2ND - SIDE EXT. WALL @ BATH

**SHEARWALL PROPERTIES:**

WALL HEIGHT, H  FT.      MAX WALL OPENING HT, H<sub>c</sub>  FT.  
WALL LENGTH, L  FT.      QUALIFYING WALL LENGTH, L  FT.      SHEARWALL ASSEMBLY

**CAPACITY EVALUATION:**

TOTAL SHEAR LOAD ON WALL  LBS < ALLOWABLE SHEARWALL CAPACITY  LBS

**SHEARWALL ASSEMBLY SPECIFICATION**

P1 - 1-SIDE 7/16" OSB  
FASTENED W/ 8D NAILS AT 6"D.C. PANEL EDGES & 12"D.C. PANEL FIELD - EDGES BLOCKED  
**ADEQUATE**

**OVERTURNING EVALUATION:**

RESISTIVE DL  PLF      OVERTURNING MOMENT  K-FT      HOLD DOWN DESIGN LOAD  LBS  
DL AT ENDS OF WALL  LBS      RESISTIVE MOMENT  K-FT      HOLDOWN CAPACITY  LBS

**HOLD-DOWN SPECIFICATION**

**SIMPSON GS 16 STRAP TIE (14" END LENGTH)**



**SHEARWALL DESIGN SUMMARY**

**SHEARWALL 205:** 2ND - SIDE INT. WALL @ BED 3

**SHEARWALL PROPERTIES:**

WALL HEIGHT, H  FT.      MAX WALL OPENING HT, H<sub>c</sub>  FT.  
WALL LENGTH, L  FT.      QUALIFYING WALL LENGTH, L  FT.      SHEARWALL ASSEMBLY

**CAPACITY EVALUATION:**

TOTAL SHEAR LOAD ON WALL  LBS < ALLOWABLE SHEARWALL CAPACITY  LBS

**SHEARWALL ASSEMBLY SPECIFICATION**

P1 - 1-SIDE 7/16" OSB  
FASTENED W/ 8D NAILS AT 6"O.C. PANEL EDGES & 12"O.C. PANEL FIELD - EDGES BLOCKED  
**ADEQUATE**

**OVERTURNING EVALUATION:**

RESISTIVE DL  PLF      OVERTURNING MOMENT  K-FT      UPLIFT CONNECTOR DESIGN LOAD  LBS  
DL AT ENDS OF WALL  LBS      RESISTIVE MOMENT  K-FT      HOLDOWN CAPACITY  LBS

**HOLD-DOWN SPECIFICATION**

**SIMPSON GS 16 STRAP TIE (14" END LENGTH)**

**SHEARWALL 206:** 2ND - FRONT EXT. WALL @ BED 2

**SHEARWALL PROPERTIES:**

WALL HEIGHT, H  FT.      MAX WALL OPENING HT, H<sub>c</sub>  FT.  
WALL LENGTH, L  FT.      QUALIFYING WALL LENGTH, L  FT.      SHEARWALL ASSEMBLY

**CAPACITY EVALUATION:**

TOTAL SHEAR LOAD ON WALL  LBS < ALLOWABLE SHEARWALL CAPACITY  LBS

**SHEARWALL ASSEMBLY SPECIFICATION**

P3 - 1-SIDE 7/16" OSB  
FASTENED W/ 8D NAILS AT 3"O.C. PANEL EDGES & 12"O.C. PANEL FIELD - EDGES BLOCKED  
**ADEQUATE**

**OVERTURNING EVALUATION:**

RESISTIVE DL  PLF      OVERTURNING MOMENT  K-FT      HOLD DOWN DESIGN LOAD  LBS  
DL AT ENDS OF WALL  LBS      RESISTIVE MOMENT  K-FT      HOLDOWN CAPACITY  LBS

**HOLD-DOWN SPECIFICATION**

**SIMPSON GS 16 STRAP TIE (14" END LENGTH)**



**SHEARWALL DESIGN SUMMARY**

**SHEARWALL 207:** 2ND - FRONT EXT. WALL @ BED 3

**SHEARWALL PROPERTIES:**

WALL HEIGHT, H  FT.      MAX WALL OPENING HT, H<sub>c</sub>  FT.  
WALL LENGTH, L  FT.      QUALIFYING WALL LENGTH, L  FT.      SHEARWALL ASSEMBLY

**CAPACITY EVALUATION:**

TOTAL SHEAR LOAD ON WALL  LBS < ALLOWABLE SHEARWALL CAPACITY  LBS

**SHEARWALL ASSEMBLY SPECIFICATION**

P3 - 1-SIDE 7/16" OSB  
FASTENED W/ 8D NAILS AT 3"D.C. PANEL EDGES & 12"D.C. PANEL FIELD - EDGES BLOCKED  
**ADEQUATE**

**OVERTURNING EVALUATION:**

RESISTIVE DL  PLF      OVERTURNING MOMENT  K-FT      UPLIFT CONNECTOR DESIGN LOAD  LBS  
DL AT ENDS OF WALL  LBS      RESISTIVE MOMENT  K-FT      HOLDOWN CAPACITY  LBS

**HOLD-DOWN SPECIFICATION**

**SIMPSON CS 16 STRAP TIE (14" END LENGTH)**

**SHEARWALL 208:** 2ND - REAR EXT. WALL @ MASTER BATH TO WIC

**SHEARWALL PROPERTIES:**

WALL HEIGHT, H  FT.      MAX WALL OPENING HT, H<sub>c</sub>  FT.  
WALL LENGTH, L  FT.      QUALIFYING WALL LENGTH, L  FT.      SHEARWALL ASSEMBLY

**CAPACITY EVALUATION:**

TOTAL SHEAR LOAD ON WALL  LBS < ALLOWABLE SHEARWALL CAPACITY  LBS

**SHEARWALL ASSEMBLY SPECIFICATION**

P1 - 1-SIDE 7/16" OSB  
FASTENED W/ 8D NAILS AT 6"D.C. PANEL EDGES & 12"D.C. PANEL FIELD - EDGES BLOCKED  
**ADEQUATE**

**OVERTURNING EVALUATION:**

RESISTIVE DL  PLF      OVERTURNING MOMENT  K-FT      HOLD DOWN DESIGN LOAD  LBS  
DL AT ENDS OF WALL  LBS      RESISTIVE MOMENT  K-FT      HOLDOWN CAPACITY  LBS

**HOLD-DOWN SPECIFICATION**

**SIMPSON CS 16 STRAP TIE (14" END LENGTH)**



**SHEARWALL DESIGN SUMMARY**

**SHEARWALL XXX:** - NOT USED

**SHEARWALL PROPERTIES:**

WALL HEIGHT, H  FT. MAX WALL OPENING HT, H<sub>c</sub>  FT.  
WALL LENGTH, L  FT. QUALIFYING WALL LENGTH, L  FT. SHEARWALL ASSEMBLY

**CAPACITY EVALUATION:**

TOTAL SHEAR LOAD ON WALL  LBS ALLOWABLE SHEARWALL CAPACITY  LBS  
 LBS **###**  LBS

**SHEARWALL ASSEMBLY SPECIFICATION**

P1 - 1-SIDE 7/16" OSB  
FASTENED W/ 8D NAILS AT 6"O.C. PANEL EDGES & 12"O.C. PANEL FIELD - EDGES BLOCKED  
**#DIV/0!**

**OVERTURNING EVALUATION:**

RESISTIVE DL  PLF OVERTURNING MOMENT  K-FT UPLIFT CONNECTOR DESIGN LOAD  LBS  
DL AT ENDS OF WALL  LBS RESISTIVE MOMENT  K-FT HOLDOWN CAPACITY  LBS

**HOLD-DOWN SPECIFICATION**

**NO HOLDOWN REQUIRED**

**SHEARWALL 101:** 1ST - SIDE EXT. WALL @ GARAGE

**SHEARWALL PROPERTIES:**

WALL HEIGHT, H  FT. MAX WALL OPENING HT, H<sub>c</sub>  FT.  
WALL LENGTH, L  FT. QUALIFYING WALL LENGTH, L  FT. SHEARWALL ASSEMBLY

**CAPACITY EVALUATION:**

TOTAL SHEAR LOAD ON WALL  LBS ALLOWABLE SHEARWALL CAPACITY  LBS  
 LBS <  LBS

**SHEARWALL ASSEMBLY SPECIFICATION**

P1 - 1-SIDE 7/16" OSB  
FASTENED W/ 8D NAILS AT 6"O.C. PANEL EDGES & 12"O.C. PANEL FIELD - EDGES BLOCKED  
**ADEQUATE**

**OVERTURNING EVALUATION:**

RESISTIVE DL  PLF OVERTURNING MOMENT  K-FT HOLD DOWN DESIGN LOAD  LBS  
DL AT ENDS OF WALL  LBS RESISTIVE MOMENT  K-FT HOLDOWN CAPACITY  LBS

**HOLD-DOWN SPECIFICATION**

**NO HOLDOWN REQUIRED**



**SHEARWALL DESIGN SUMMARY**

**SHEARWALL 102:** 1ST - SIDE EXT. WALL @ GREAT ROOM

**SHEARWALL PROPERTIES:**

WALL HEIGHT, H  FT.      MAX WALL OPENING HT, H<sub>c</sub>  FT.  
WALL LENGTH, L  FT.      QUALIFYING WALL LENGTH, L  FT.      SHEARWALL ASSEMBLY

**CAPACITY EVALUATION:**

TOTAL SHEAR LOAD ON WALL  LBS < ALLOWABLE SHEARWALL CAPACITY  LBS

**SHEARWALL ASSEMBLY SPECIFICATION**

**P3-BS - 2-SIDES 7/16" OSB**  
FASTENED W/ 8D NAILS AT 3"D.C. PANEL EDGES & 12"D.C. PANEL FIELD - EDGES BLOCKED  
**ADEQUATE**

**OVERTURNING EVALUATION:**

RESISTIVE DL  PLF      OVERTURNING MOMENT  K-FT      UPLIFT CONNECTOR DESIGN LOAD  LBS  
DL AT ENDS OF WALL  LBS      RESISTIVE MOMENT  K-FT      HOLDOWN CAPACITY  LBS

**HOLD-DOWN SPECIFICATION**

**SIMPSON MSTC66 STRAP TIE (20" END LENGTH)**

**SHEARWALL 103:** 1ST - SIDE INT. WALL @ GARAGE

**SHEARWALL PROPERTIES:**

WALL HEIGHT, H  FT.      MAX WALL OPENING HT, H<sub>c</sub>  FT.  
WALL LENGTH, L  FT.      QUALIFYING WALL LENGTH, L  FT.      SHEARWALL ASSEMBLY

**CAPACITY EVALUATION:**

TOTAL SHEAR LOAD ON WALL  LBS < ALLOWABLE SHEARWALL CAPACITY  LBS

**SHEARWALL ASSEMBLY SPECIFICATION**

**P1 - 1-SIDE 7/16" OSB**  
FASTENED W/ 8D NAILS AT 6"D.C. PANEL EDGES & 12"D.C. PANEL FIELD - EDGES BLOCKED  
**ADEQUATE**

**OVERTURNING EVALUATION:**

RESISTIVE DL  PLF      OVERTURNING MOMENT  K-FT      HOLD DOWN DESIGN LOAD  LBS  
DL AT ENDS OF WALL  LBS      RESISTIVE MOMENT  K-FT      HOLDOWN CAPACITY  LBS

**HOLD-DOWN SPECIFICATION**

**SIMPSON STHD14RJ HOLDOWN**



**SHEARWALL DESIGN SUMMARY**

**SHEARWALL 104:** 1ST - SIDE EXT. WALL @ OFFICE

**SHEARWALL PROPERTIES:**

WALL HEIGHT, H  FT.      MAX WALL OPENING HT, H<sub>c</sub>  FT.  
WALL LENGTH, L  FT.      QUALIFYING WALL LENGTH, L  FT.      SHEARWALL ASSEMBLY

**CAPACITY EVALUATION:**

TOTAL SHEAR LOAD ON WALL  LBS      <      ALLOWABLE SHEARWALL CAPACITY  LBS

**SHEARWALL ASSEMBLY SPECIFICATION**

P1 - 1-SIDE 7/16" OSB  
FASTENED W/ 8D NAILS AT 6"O.C. PANEL EDGES & 12"O.C. PANEL FIELD - EDGES BLOCKED  
**ADEQUATE**

**OVERTURNING EVALUATION:**

RESISTIVE DL  PLF      OVERTURNING MOMENT  K-FT      UPLIFT CONNECTOR DESIGN LOAD  LBS  
DL AT ENDS OF WALL  LBS      RESISTIVE MOMENT  K-FT      HOLDOWN CAPACITY  LBS

**HOLD-DOWN SPECIFICATION**

**SIMPSON MSTC66 STRAP TIE (20" END LENGTH)**

**SHEARWALL 105:** 1ST - FRONT EXT. WALL @ GREAT ROOM

**SHEARWALL PROPERTIES:**

WALL HEIGHT, H  FT.      MAX WALL OPENING HT, H<sub>c</sub>  FT.  
WALL LENGTH, L  FT.      QUALIFYING WALL LENGTH, L  FT.      SHEARWALL ASSEMBLY

**CAPACITY EVALUATION:**

TOTAL SHEAR LOAD ON WALL  LBS      <      ALLOWABLE SHEARWALL CAPACITY  LBS

**SHEARWALL ASSEMBLY SPECIFICATION**

P3 - 1-SIDE 7/16" OSB  
FASTENED W/ 8D NAILS AT 3"O.C. PANEL EDGES & 12"O.C. PANEL FIELD - EDGES BLOCKED  
**ADEQUATE**

**OVERTURNING EVALUATION:**

RESISTIVE DL  PLF      OVERTURNING MOMENT  K-FT      HOLD DOWN DESIGN LOAD  LBS  
DL AT ENDS OF WALL  LBS      RESISTIVE MOMENT  K-FT      HOLDOWN CAPACITY  LBS

**HOLD-DOWN SPECIFICATION**

**SIMPSON STHD14RJ HOLDOWN**



**SHEARWALL DESIGN SUMMARY**

**SHEARWALL 106:** 1ST - FRONT EXT. WALL @ OFFICE

**SHEARWALL PROPERTIES:**

WALL HEIGHT, H  FT.      MAX WALL OPENING HT, H<sub>c</sub>  FT.  
WALL LENGTH, L  FT.      QUALIFYING WALL LENGTH, L  FT.      SHEARWALL ASSEMBLY

**CAPACITY EVALUATION:**

TOTAL SHEAR LOAD ON WALL  LBS < ALLOWABLE SHEARWALL CAPACITY  LBS

**SHEARWALL ASSEMBLY SPECIFICATION**

**P3 - 1-SIDE 7/16" OSB**  
FASTENED W/ 8D NAILS AT 3"D.C. PANEL EDGES & 12"D.C. PANEL FIELD - EDGES BLOCKED  
**ADEQUATE**

**OVERTURNING EVALUATION:**

RESISTIVE DL  PLF      OVERTURNING MOMENT  K-FT      UPLIFT CONNECTOR DESIGN LOAD  LBS  
DL AT ENDS OF WALL  LBS      RESISTIVE MOMENT  K-FT      HOLDOWN CAPACITY  LBS

**HOLD-DOWN SPECIFICATION**

**SIMPSON STDH14RJ HOLDOWN**

**SHEARWALL 107:** 1ST - REAR EXT. WALL @ KITCHEN

**SHEARWALL PROPERTIES:**

WALL HEIGHT, H  FT.      MAX WALL OPENING HT, H<sub>c</sub>  FT.  
WALL LENGTH, L  FT.      QUALIFYING WALL LENGTH, L  FT.      SHEARWALL ASSEMBLY

**CAPACITY EVALUATION:**

TOTAL SHEAR LOAD ON WALL  LBS < ALLOWABLE SHEARWALL CAPACITY  LBS

**SHEARWALL ASSEMBLY SPECIFICATION**

**P3 - 1-SIDE 7/16" OSB**  
FASTENED W/ 8D NAILS AT 3"D.C. PANEL EDGES & 12"D.C. PANEL FIELD - EDGES BLOCKED  
**ADEQUATE**

**OVERTURNING EVALUATION:**

RESISTIVE DL  PLF      OVERTURNING MOMENT  K-FT      HOLD DOWN DESIGN LOAD  LBS  
DL AT ENDS OF WALL  LBS      RESISTIVE MOMENT  K-FT      HOLDOWN CAPACITY  LBS

**HOLD-DOWN SPECIFICATION**

**NO HOLDOWN REQUIRED**





**SHEARWALL DESIGN SUMMARY**

**SHEARWALL 108:** 1ST - REAR EXT. WALL @ GARAGE

**SHEARWALL PROPERTIES:**

WALL HEIGHT, H  FT.      MAX WALL OPENING HT, H<sub>c</sub>  FT.  
WALL LENGTH, L  FT.      QUALIFYING WALL LENGTH, L  FT.      SHEARWALL ASSEMBLY

**CAPACITY EVALUATION:**

TOTAL SHEAR LOAD ON WALL  LBS      <      ALLOWABLE SHEARWALL CAPACITY  LBS

**SHEARWALL ASSEMBLY SPECIFICATION**

**P3 - 1-SIDE 7/16" OSB**  
FASTENED W/ 8D NAILS AT 3"D.C. PANEL EDGES & 12"D.C. PANEL FIELD - EDGES BLOCKED  
**ADEQUATE**

**OVERTURNING EVALUATION:**

RESISTIVE DL  PLF      OVERTURNING MOMENT  K-FT      UPLIFT CONNECTOR DESIGN LOAD  LBS  
DL AT ENDS OF WALL  LBS      RESISTIVE MOMENT  K-FT      HOLDOWN CAPACITY  LBS

**HOLD-DOWN SPECIFICATION**

**SIMPSON STHD14RJ HOLDOWN**

**SHEARWALL XXX:** - NOT USED

**SHEARWALL PROPERTIES:**

WALL HEIGHT, H  FT.      MAX WALL OPENING HT, H<sub>c</sub>  FT.  
WALL LENGTH, L  FT.      QUALIFYING WALL LENGTH, L  FT.      SHEARWALL ASSEMBLY

**CAPACITY EVALUATION:**

TOTAL SHEAR LOAD ON WALL  LBS      ###      ALLOWABLE SHEARWALL CAPACITY  LBS

**SHEARWALL ASSEMBLY SPECIFICATION**

**P1 - 1-SIDE 7/16" OSB**  
FASTENED W/ 8D NAILS AT 6"D.C. PANEL EDGES & 12"D.C. PANEL FIELD - EDGES BLOCKED  
**#DIV/0!**

**OVERTURNING EVALUATION:**

RESISTIVE DL  PLF      OVERTURNING MOMENT  K-FT      HOLD DOWN DESIGN LOAD  LBS  
DL AT ENDS OF WALL  LBS      RESISTIVE MOMENT  K-FT      HOLDOWN CAPACITY  LBS

**HOLD-DOWN SPECIFICATION**

**NO HOLDOWN REQUIRED**



**SHEARWALL DESIGN SUMMARY**

**SHEARWALL 1: BASEMENT - SIDE INT. WALL @ STAIRS**

**SHEARWALL PROPERTIES:**

WALL HEIGHT, H  FT. MAX WALL OPENING HT, H<sub>c</sub>  FT.  
WALL LENGTH, L  FT. QUALIFYING WALL LENGTH, L  FT. SHEARWALL ASSEMBLY

**CAPACITY EVALUATION:**

TOTAL SHEAR LOAD ON WALL  LBS < ALLOWABLE SHEARWALL CAPACITY  LBS

**SHEARWALL ASSEMBLY SPECIFICATION**

P3 - 1-SIDE 7/16" OSB  
FASTENED W/ 8D NAILS AT 3"D.C. PANEL EDGES & 12"D.C. PANEL FIELD - EDGES BLOCKED  
**ADEQUATE**

**OVERTURNING EVALUATION:**

RESISTIVE DL  PLF OVERTURNING MOMENT  K-FT UPLIFT CONNECTOR DESIGN LOAD  LBS  
DL AT ENDS OF WALL  LBS RESISTIVE MOMENT  K-FT HOLDOWN CAPACITY  LBS

**HOLD-DOWN SPECIFICATION**

**SIMPSON STHD14RJ HOLDOWN**

**SHEARWALL 2: BASEMENT - SIDE INT. WALL @ BED 5**

**SHEARWALL PROPERTIES:**

WALL HEIGHT, H  FT. MAX WALL OPENING HT, H<sub>c</sub>  FT.  
WALL LENGTH, L  FT. QUALIFYING WALL LENGTH, L  FT. SHEARWALL ASSEMBLY

**CAPACITY EVALUATION:**

TOTAL SHEAR LOAD ON WALL  LBS < ALLOWABLE SHEARWALL CAPACITY  LBS

**SHEARWALL ASSEMBLY SPECIFICATION**

P1 - 1-SIDE 7/16" OSB  
FASTENED W/ 8D NAILS AT 6"D.C. PANEL EDGES & 12"D.C. PANEL FIELD - EDGES BLOCKED  
**ADEQUATE**

**OVERTURNING EVALUATION:**

RESISTIVE DL  PLF OVERTURNING MOMENT  K-FT HOLD DOWN DESIGN LOAD  LBS  
DL AT ENDS OF WALL  LBS RESISTIVE MOMENT  K-FT HOLDOWN CAPACITY  LBS

**HOLD-DOWN SPECIFICATION**

**SIMPSON STHD14RJ HOLDOWN**



**SHEARWALL DESIGN SUMMARY**

**SHEARWALL 3: BASEMENT - SIDE INT. WALL @ BASEMENT TO CRAWL**

**SHEARWALL PROPERTIES:**

WALL HEIGHT, H  FT.      MAX WALL OPENING HT, H<sub>c</sub>  FT.  
WALL LENGTH, L  FT.      QUALIFYING WALL LENGTH, L  FT.      SHEARWALL ASSEMBLY

**CAPACITY EVALUATION:**

TOTAL SHEAR LOAD ON WALL  LBS      <      ALLOWABLE SHEARWALL CAPACITY  LBS

**SHEARWALL ASSEMBLY SPECIFICATION**

P1 - 1-SIDE 7/16" OSB  
FASTENED W/ 8D NAILS AT 6"O.C. PANEL EDGES & 12"O.C. PANEL FIELD - EDGES BLOCKED  
**ADEQUATE**

**OVERTURNING EVALUATION:**

RESISTIVE DL  PLF      OVERTURNING MOMENT  K-FT      UPLIFT CONNECTOR DESIGN LOAD  LBS  
DL AT ENDS OF WALL  LBS      RESISTIVE MOMENT  K-FT      HOLDOWN CAPACITY  LBS

**HOLD-DOWN SPECIFICATION**

**NO HOLDOWN REQUIRED**

**SHEARWALL XXX: - NOT USED**

**SHEARWALL PROPERTIES:**

WALL HEIGHT, H  FT.      MAX WALL OPENING HT, H<sub>c</sub>  FT.  
WALL LENGTH, L  FT.      QUALIFYING WALL LENGTH, L  FT.      SHEARWALL ASSEMBLY

**CAPACITY EVALUATION:**

TOTAL SHEAR LOAD ON WALL  LBS      ###      ALLOWABLE SHEARWALL CAPACITY  LBS

**SHEARWALL ASSEMBLY SPECIFICATION**

P1 - 1-SIDE 7/16" OSB  
FASTENED W/ 8D NAILS AT 6"O.C. PANEL EDGES & 12"O.C. PANEL FIELD - EDGES BLOCKED  
**#DIV/0!**

**OVERTURNING EVALUATION:**

RESISTIVE DL  PLF      OVERTURNING MOMENT  K-FT      HOLD DOWN DESIGN LOAD  LBS  
DL AT ENDS OF WALL  LBS      RESISTIVE MOMENT  K-FT      HOLDOWN CAPACITY  LBS

**HOLD-DOWN SPECIFICATION**

**NO HOLDOWN REQUIRED**

This Wall in File: P:\Client Files\203 - Architectural Innovations\2020\20001 - Pratt Plat

RetainPro (c) 1987-2019, Build 11.20.03.31

License : KW-06059959

License To : **MULHERN & KULP STRUCTURAL ENGINEERING INC**

### Cantilevered Retaining Wall

#### Criteria

Retained Height	=	8.33 ft
Wall height above soil	=	0.67 ft
Slope Behind Wall	=	0.00
Height of Soil over Toe	=	0.00 in
Water height over heel	=	0.0 ft

#### Soil Data

Allow Soil Bearing	=	3,000.0 psf
Equivalent Fluid Pressure Method		
Active Heel Pressure	=	35.0 psf/ft
Passive Pressure	=	350.0 psf/ft
Soil Density, Heel	=	110.00 pcf
Soil Density, Toe	=	0.00 pcf
Footings  Soil Friction	=	0.350
Soil height to ignore for passive pressure	=	12.00 in

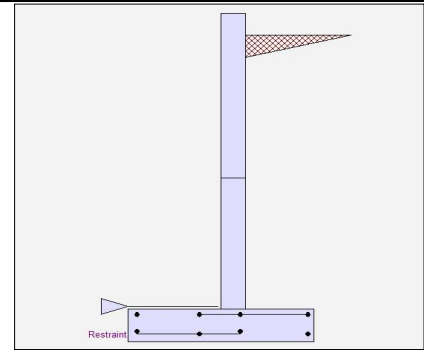

#### Surcharge Loads

Surcharge Over Heel	=	0.0 psf
Used To Resist Sliding & Overturning		
Surcharge Over Toe	=	0.0 psf
Used for Sliding & Overturning		

#### Lateral Load Applied to Stem

Lateral Load	=	0.0 #/ft
...Height to Top	=	0.00 ft
...Height to Bottom	=	0.00 ft
Load Type	=	Wind (W) (Service Level)
Wind on Exposed Stem	=	0.0 psf (Service Level)

#### Adjacent Footing Load

Adjacent Footing Load	=	0.0 lbs
Footing Width	=	0.00 ft
Eccentricity	=	0.00 in
Wall to Ftg CL Dist	=	0.00 ft
Footing Type	=	Line Load
Base Above/Below Soil at Back of Wall	=	0.0 ft
Poisson's Ratio	=	0.300

#### Axial Load Applied to Stem

Axial Dead Load	=	100.0 lbs
Axial Live Load	=	0.0 lbs
Axial Load Eccentricity	=	0.0 in

#### Earth Pressure Seismic Load

Method : Uniform		
Multiplier Used	=	7.000
(Multiplier used on soil density)		
Uniform Seismic Force	=	65.310
Total Seismic Force	=	609.342

#### Design Summary

##### Wall Stability Ratios

Overturning	=	2.22 OK
Slab Resists All Sliding !		
Total Bearing Load	=	4,102 lbs
...resultant ecc.	=	1.30 in
Soil Pressure @ Toe	=	775 psf OK
Soil Pressure @ Heel	=	597 psf OK
Allowable	=	3,000 psf
Soil Pressure Less Than Allowable		
ACI Factored @ Toe	=	1,085 psf
ACI Factored @ Heel	=	835 psf
Footing Shear @ Toe	=	15.1 psi OK
Footing Shear @ Heel	=	15.8 psi OK
Allowable	=	75.0 psi

##### Sliding Calcs

Lateral Sliding Force	=	1,949.9 lbs
-----------------------	---	-------------

#### Stem Construction

	2nd	Bottom
Design Height Above Ftg	ft = 4.00	0.00
Wall Material Above "Ht"	= Concrete	Concrete
Design Method	= LFRD	LFRD
Thickness	= 8.00	8.00
Rebar Size	= # 5	# 5
Rebar Spacing	= 16.00	8.00
Rebar Placed at	= Edge	Edge

##### Design Data

fb/FB + fa/Fa	=	0.219	0.638
<b>Total Force @ Section</b>			
Service Level	lbs =		
Strength Level	lbs =	807.8	2,486.9
<b>Moment....Actual</b>			
Service Level	ft-# =		
Strength Level	ft-# =	1,370.0	7,660.7
Moment....Allowable	ft-# =	6,234.5	11,990.5
<b>Shear.....Actual</b>			
Service Level	psi =		
Strength Level	psi =	10.9	33.5
Shear.....Allowable	psi =	82.2	82.2
Anet (Masonry)	in2 =		
Rebar Depth 'd'	in =	6.19	6.19

##### Masonry Data

f'm	psi =		
Fs	psi =		
Solid Grouting	=		
Modular Ratio 'n'	=		
Wall Weight	psf =	100.0	100.0
Short Term Factor	=		
Equiv. Solid Thick.	=		
Masonry Block Type	=	Medium Weight	
Masonry Design Method	=	ASD	

##### Concrete Data

f'c	psi =	3,000.0	3,000.0
Fy	psi =	60,000.0	60,000.0

Vertical component of active lateral soil pressure IS considered in the calculation of soil bearing pressures.

##### Load Factors

Building Code	IBC 2015,ACI
Dead Load	1.200
Live Load	1.600
Earth, H	1.600
Wind, W	1.000
Seismic, E	1.000

**Basement Cantilevered Wall**

This Wall in File: P:\Client Files\203 - Architectural Innovations\2020\20001 - Pratt Plat

RetainPro (c) 1987-2019, Build 11.20.03.31  
License : KW-06059959  
License To : **MULHERN & KULP STRUCTURAL ENGINEERING INC**

**Cantilevered Retaining Wall**

**Concrete Stem Rebar Area Details**

2nd Stem	Vertical Reinforcing	Horizontal Reinforcing	
As (based on applied moment) :	0.0519 in2/ft		
(4/3) * As :	0.0692 in2/ft	Min Stem T&S Reinf Area 0.960 in2	
200bd/fy : 200(12)(6.1875)/60000 :	0.2475 in2/ft	Min Stem T&S Reinf Area per ft of stem Height : 0.192 in2/ft	
0.0018bh : 0.0018(12)(8) :	0.1728 in2/ft	Horizontal Reinforcing Options :	
	=====	One layer of :	Two layers of :
Required Area :	0.1728 in2/ft	#4@ 12.50 in	#4@ 25.00 in
Provided Area :	0.2325 in2/ft	#5@ 19.38 in	#5@ 38.75 in
Maximum Area :	1.0059 in2/ft	#6@ 27.50 in	#6@ 55.00 in

Bottom Stem	Vertical Reinforcing	Horizontal Reinforcing	
As (based on applied moment) :	0.2901 in2/ft		
(4/3) * As :	0.3868 in2/ft	Min Stem T&S Reinf Area 0.768 in2	
200bd/fy : 200(12)(6.1875)/60000 :	0.2475 in2/ft	Min Stem T&S Reinf Area per ft of stem Height : 0.192 in2/ft	
0.0018bh : 0.0018(12)(8) :	0.1728 in2/ft	Horizontal Reinforcing Options :	
	=====	One layer of :	Two layers of :
Required Area :	0.2901 in2/ft	#4@ 12.50 in	#4@ 25.00 in
Provided Area :	0.465 in2/ft	#5@ 19.38 in	#5@ 38.75 in
Maximum Area :	1.0059 in2/ft	#6@ 27.50 in	#6@ 55.00 in

**Footing Data**

Toe Width	=	2.50 ft
Heel Width	=	2.50
Total Footing Width	=	5.00
Footing Thickness	=	12.00 in
Key Width	=	0.00 in
Key Depth	=	0.00 in
Key Distance from Toe	=	0.00 ft
f'c =	2,500 psi	Fy = 60,000 psi
Footing Concrete Density	=	150.00 pcf
Min. As %	=	0.0018
Cover @ Top	2.00	@ Btm.= 3.00 in

**Footing Design Results**

		<b>Toe</b>	<b>Heel</b>
Factored Pressure	=	1,085	835 psf
Mu' : Upward	=	39,139	1,455 ft-#
Mu' : Downward	=	6,750	4,123 ft-#
Mu: Design	=	2,699	2,668 ft-#
Actual 1-Way Shear	=	15.12	15.84 psi
Allow 1-Way Shear	=	75.00	75.00 psi
Toe Reinforcing	=	# 5 @ 8.00 in	
Heel Reinforcing	=	# 4 @ 8.00 in	
Key Reinforcing	=	None Spec'd	
Footing Torsion, Tu	=		0.00 ft-lbs
Footing Allow. Torsion, phi Tu	=		0.00 ft-lbs

**If torsion exceeds allowable, provide supplemental design for footing torsion.**

**Other Acceptable Sizes & Spacings**

Toe: #4@ 9.25 in, #5@ 14.35 in, #6@ 20.37 in, #7@ 27.77 in, #8@ 36.57 in, #9@ 46  
Heel: #4@ 9.25 in, #5@ 14.35 in, #6@ 20.37 in, #7@ 27.77 in, #8@ 36.57 in, #9@ 46  
Key: No key defined

Min footing T&S reinf Area	1.30	in2
Min footing T&S reinf Area per foot	0.26	in2 /ft
If one layer of horizontal bars:	If two layers of horizontal bars:	
#4@ 9.26 in	#4@ 18.52 in	
#5@ 14.35 in	#5@ 28.70 in	
#6@ 20.37 in	#6@ 40.74 in	

This Wall in File: P:\Client Files\203 - Architectural Innovations\2020\20001 - Pratt Plat

RetainPro (c) 1987-2019, Build 11.20.03.31

License : KW-06059959

License To : MULHERN &amp; KULP STRUCTURAL ENGINEERING INC

**Cantilevered Retaining Wall****Summary of Overturning & Resisting Forces & Moments**

Item	.....OVERTURNING.....			.....RESISTING.....			
	Force lbs	Distance ft	Moment ft-#	Force lbs	Distance ft	Moment ft-#	
HL Act Pres (ab water tbl)	1,523.4	3.11	4,737.6	Soil Over HL (ab. water tbl)	1,679.9	4.08	6,859.5
HL Act Pres (be water tbl)				Soil Over HL (bel. water tbl)		4.08	6,859.5
Hydrostatic Force				Watre Table			
Buoyant Force =				Sloped Soil Over Heel =			
Surcharge over Heel =				Surcharge Over Heel =			
Surcharge Over Toe =				Adjacent Footing Load =			
Adjacent Footing Load =				Axial Dead Load on Stem =	100.0	2.83	283.3
Added Lateral Load =				* Axial Live Load on Stem =			
Load @ Stem Above Soil =				Soil Over Toe =			
Seismic Earth Load =	426.5	4.67	1,989.8	Surcharge Over Toe =			
=				Stem Weight(s) =	900.0	2.83	2,550.0
<b>Total</b> =	<b>1,949.9</b>	<b>O.T.M.</b>	<b>= 6,727.4</b>	Earth @ Stem Transitions =			
				Footing Weight =	750.0	2.50	1,875.0
				Key Weight =			
				Vert. Component =	672.4	5.00	3,362.2
				<b>Total =</b>	<b>4,102.3 lbs</b>	<b>R.M.=</b>	<b>14,930.0</b>

**Resisting/Overturning Ratio**= **2.22**

Vertical Loads used for Soil Pressure = 4,102.3 lbs

\* Axial live load NOT included in total displayed, or used for overturning resistance, but is included for soil pressure calculation.

If seismic is included, the OTM and sliding ratios may be 1.1 per section 1807.2.3 of IBC.

Vertical component of active lateral soil pressure IS considered in the calculation of Sliding Resistance.

Vertical component of active lateral soil pressure IS considered in the calculation of Overturning Resistance.

**Tilt****Horizontal Deflection at Top of Wall due to settlement of soil**

(Deflection due to wall bending not considered)

Soil Spring Reaction Modulus 250.0 pci

Horizontal Defl @ Top of Wall (approximate only) 0.039 in

The above calculation is not valid if the heel soil bearing pressure exceeds that of the toe, because the wall would then tend to rotate into the retained soil.

This Wall in File: P:\Client Files\203 - Architectural Innovations\2020\20001 - Pratt Plat

RetainPro (c) 1987-2019, Build 11.20.03.31

License : KW-06059959

License To : **MULHERN & KULP STRUCTURAL ENGINEERING INC**

### Cantilevered Retaining Wall

#### Criteria

Retained Height	=	10.00 ft
Wall height above soil	=	0.38 ft
Slope Behind Wall	=	0.00
Height of Soil over Toe	=	0.00 in
Water height over heel	=	0.0 ft

#### Soil Data

Allow Soil Bearing	=	3,000.0 psf
Equivalent Fluid Pressure Method		
Active Heel Pressure	=	35.0 psf/ft
	=	
Passive Pressure	=	350.0 psf/ft
Soil Density, Heel	=	110.00 pcf
Soil Density, Toe	=	0.00 pcf
Footing  Soil Friction	=	0.350
Soil height to ignore for passive pressure	=	12.00 in

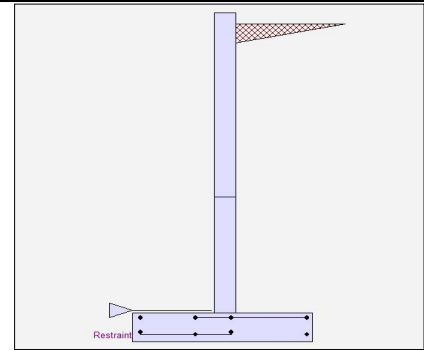

#### Surcharge Loads

Surcharge Over Heel	=	0.0 psf
Used To Resist Sliding & Overturning		
Surcharge Over Toe	=	0.0 psf
Used for Sliding & Overturning		

#### Lateral Load Applied to Stem

Lateral Load	=	0.0 #/ft
...Height to Top	=	0.00 ft
...Height to Bottom	=	0.00 ft
Load Type	=	Wind (W) (Service Level)
Wind on Exposed Stem	=	0.0 psf (Service Level)

#### Adjacent Footing Load

Adjacent Footing Load	=	0.0 lbs
Footing Width	=	0.00 ft
Eccentricity	=	0.00 in
Wall to Ftg CL Dist	=	0.00 ft
Footing Type		Line Load
Base Above/Below Soil at Back of Wall	=	0.0 ft
Poisson's Ratio	=	0.300

#### Axial Load Applied to Stem

Axial Dead Load	=	100.0 lbs
Axial Live Load	=	0.0 lbs
Axial Load Eccentricity	=	0.0 in

#### Earth Pressure Seismic Load

Method : Uniform		
Multiplier Used	=	7.000
(Multiplier used on soil density)		
Uniform Seismic Force	=	77.000
Total Seismic Force	=	847.000

#### Design Summary

##### Wall Stability Ratios

Overturning	=	1.97 OK
Slab Resists All Sliding !		
Total Bearing Load	=	5,464 lbs
...resultant ecc.	=	4.57 in
Soil Pressure @ Toe	=	1,166 psf OK
Soil Pressure @ Heel	=	481 psf OK
Allowable	=	3,000 psf
Soil Pressure Less Than Allowable		
ACI Factored @ Toe	=	1,632 psf
ACI Factored @ Heel	=	674 psf
Footing Shear @ Toe	=	22.8 psi OK
Footing Shear @ Heel	=	25.9 psi OK
Allowable	=	75.0 psi

##### Sliding Calcs

Lateral Sliding Force	=	2,710.4 lbs
-----------------------	---	-------------

#### Stem Construction

	2nd	Bottom
Design Height Above Ftg	ft = 4.00	Stem OK 0.00
Wall Material Above "Ht"	= Concrete	Concrete
Design Method	= LFRD	LFRD
Thickness	= 8.00	8.00
Rebar Size	= # 5	# 5
Rebar Spacing	= 12.00	6.00
Rebar Placed at	= Edge	Edge

##### Design Data

fb/FB + fa/Fa	=	0.414	0.847
<b>Total Force @ Section</b>			
Service Level	lbs =		
Strength Level	lbs =	1,470.0	3,570.0
<b>Moment....Actual</b>			
Service Level	ft-# =		
Strength Level	ft-# =	3,402.0	13,183.3
Moment....Allowable	ft-# =	8,206.3	15,562.2
<b>Shear.....Actual</b>			
Service Level	psi =		
Strength Level	psi =	19.8	48.1
Shear.....Allowable	psi =	82.2	82.2
Anet (Masonry)	in2 =		
Rebar Depth 'd'	in =	6.19	6.19

##### Masonry Data

f'm	psi =		
Fs	psi =		
Solid Grouting	=		
Modular Ratio 'n'	=		
Wall Weight	psf =	100.0	100.0
Short Term Factor	=		
Equiv. Solid Thick.	=		
Masonry Block Type	=	Medium Weight	
Masonry Design Method	=	ASD	

##### Concrete Data

f'c	psi =	3,000.0	3,000.0
Fy	psi =	60,000.0	60,000.0

Vertical component of active lateral soil pressure IS considered in the calculation of soil bearing pressures.

##### Load Factors

Building Code	IBC 2015,ACI
Dead Load	1.200
Live Load	1.600
Earth, H	1.600
Wind, W	1.000
Seismic, E	1.000

This Wall in File: P:\Client Files\203 - Architectural Innovations\2020\20001 - Pratt Plat

RetainPro (c) 1987-2019, Build 11.20.03.31  
License : KW-06059959  
License To : MULHERN & KULP STRUCTURAL ENGINEERING INC

### Cantilevered Retaining Wall

#### Concrete Stem Rebar Area Details

2nd Stem	Vertical Reinforcing	Horizontal Reinforcing	
As (based on applied moment) :	0.1288 in <sup>2</sup> /ft		
(4/3) * As :	0.1718 in <sup>2</sup> /ft	Min Stem T&S Reinf Area 1.225 in <sup>2</sup>	
200bd/fy : 200(12)(6.1875)/60000 :	0.2475 in <sup>2</sup> /ft	Min Stem T&S Reinf Area per ft of stem Height : 0.192 in <sup>2</sup> /ft	
0.0018bh : 0.0018(12)(8) :	0.1728 in <sup>2</sup> /ft	Horizontal Reinforcing Options :	
	=====	One layer of :	Two layers of :
Required Area :	0.1728 in <sup>2</sup> /ft	#4@ 12.50 in	#4@ 25.00 in
Provided Area :	0.31 in <sup>2</sup> /ft	#5@ 19.38 in	#5@ 38.75 in
Maximum Area :	1.0059 in <sup>2</sup> /ft	#6@ 27.50 in	#6@ 55.00 in

Bottom Stem	Vertical Reinforcing	Horizontal Reinforcing	
As (based on applied moment) :	0.4992 in <sup>2</sup> /ft		
(4/3) * As :	0.6656 in <sup>2</sup> /ft	Min Stem T&S Reinf Area 0.768 in <sup>2</sup>	
200bd/fy : 200(12)(6.1875)/60000 :	0.2475 in <sup>2</sup> /ft	Min Stem T&S Reinf Area per ft of stem Height : 0.192 in <sup>2</sup> /ft	
0.0018bh : 0.0018(12)(8) :	0.1728 in <sup>2</sup> /ft	Horizontal Reinforcing Options :	
	=====	One layer of :	Two layers of :
Required Area :	0.4992 in <sup>2</sup> /ft	#4@ 12.50 in	#4@ 25.00 in
Provided Area :	0.62 in <sup>2</sup> /ft	#5@ 19.38 in	#5@ 38.75 in
Maximum Area :	1.0059 in <sup>2</sup> /ft	#6@ 27.50 in	#6@ 55.00 in

#### Footing Data

Toe Width	=	2.50 ft
Heel Width	=	3.00
Total Footing Width	=	5.50
Footing Thickness	=	12.00 in
Key Width	=	0.00 in
Key Depth	=	0.00 in
Key Distance from Toe	=	0.00 ft
f'c =	2,500 psi	Fy = 60,000 psi
Footing Concrete Density	=	150.00 pcf
Min. As %	=	0.0018
Cover @ Top	2.00	@ Btm = 3.00 in

#### Footing Design Results

		<u>Toe</u>	<u>Heel</u>
Factored Pressure	=	1,632	674 psf
Mu' : Upward	=	55,761	2,203 ft-#
Mu' : Downward	=	6,750	7,573 ft-#
Mu: Design	=	4,084	5,370 ft-#
Actual 1-Way Shear	=	22.77	25.87 psi
Allow 1-Way Shear	=	75.00	75.00 psi
Toe Reinforcing	=	# 5 @ 6.00 in	
Heel Reinforcing	=	# 4 @ 8.00 in	
Key Reinforcing	=	None Spec'd	
Footing Torsion, Tu	=		0.00 ft-lbs
Footing Allow. Torsion, phi Tu	=		0.00 ft-lbs

**If torsion exceeds allowable, provide supplemental design for footing torsion.**

#### Other Acceptable Sizes & Spacings

Toe: #4@ 9.25 in, #5@ 14.35 in, #6@ 20.37 in, #7@ 27.77 in, #8@ 36.57 in, #9@ 46  
Heel: #4@ 9.25 in, #5@ 14.35 in, #6@ 20.37 in, #7@ 27.77 in, #8@ 36.57 in, #9@ 46  
Key: No key defined

Min footing T&S reinf Area	1.43	in <sup>2</sup>
Min footing T&S reinf Area per foot	0.26	in <sup>2</sup> /ft
If one layer of horizontal bars:	If two layers of horizontal bars:	
#4@ 9.26 in	#4@ 18.52 in	
#5@ 14.35 in	#5@ 28.70 in	
#6@ 20.37 in	#6@ 40.74 in	



This Wall in File: P:\Client Files\203 - Architectural Innovations\2020\20001 - Pratt Plat

RetainPro (c) 1987-2019, Build 11.20.03.31

License : KW-06059959

License To : MULHERN &amp; KULP STRUCTURAL ENGINEERING INC

**Cantilevered Retaining Wall****Summary of Overturning & Resisting Forces & Moments**

Item	.....OVERTURNING.....			.....RESISTING.....			
	Force lbs	Distance ft	Moment ft-#	Force lbs	Distance ft	Moment ft-#	
HL Act Pres (ab water tbl)	2,117.5	3.67	7,764.2	Soil Over HL (ab. water tbl)	2,566.7	4.33	11,122.2
HL Act Pres (be water tbl)				Soil Over HL (bel. water tbl)		4.33	11,122.2
Hydrostatic Force				Watre Table			
Buoyant Force =				Sloped Soil Over Heel =			
Surcharge over Heel =				Surcharge Over Heel =			
Surcharge Over Toe =				Adjacent Footing Load =			
Adjacent Footing Load =				Axial Dead Load on Stem =	100.0	2.83	283.3
Added Lateral Load =				* Axial Live Load on Stem =			
Load @ Stem Above Soil =				Soil Over Toe =			
Seismic Earth Load =	592.9	5.50	3,261.0	Surcharge Over Toe =			
=				Stem Weight(s) =	1,038.0	2.83	2,941.0
<b>Total</b> =	<b>2,710.4</b>	<b>O.T.M. =</b>	<b>11,025.1</b>	Earth @ Stem Transitions =			
				Footing Weight =	825.0	2.75	2,268.8
				Key Weight =			
				Vert. Component =	934.7	5.50	5,140.9
				<b>Total =</b>	<b>5,464.4 lbs</b>	<b>R.M.=</b>	<b>21,756.2</b>

**Resisting/Overturning Ratio**= **1.97**

Vertical Loads used for Soil Pressure = 5,464.4 lbs

\* Axial live load NOT included in total displayed, or used for overturning resistance, but is included for soil pressure calculation.

If seismic is included, the OTM and sliding ratios may be 1.1 per section 1807.2.3 of IBC.

Vertical component of active lateral soil pressure IS considered in the calculation of Sliding Resistance.

Vertical component of active lateral soil pressure IS considered in the calculation of Overturning Resistance.

**Tilt****Horizontal Deflection at Top of Wall due to settlement of soil**

(Deflection due to wall bending not considered)

Soil Spring Reaction Modulus 250.0 pci

Horizontal Defl @ Top of Wall (approximate only) 0.061 in

The above calculation is not valid if the heel soil bearing pressure exceeds that of the toe, because the wall would then tend to rotate into the retained soil.

This Wall in File: P:\Client Files\203 - Architectural Innovations\2020\20001 - Pratt Plat

RetainPro (c) 1987-2019, Build 11.20.03.31

License : KW-06059959

License To : MULHERN & KULP STRUCTURAL ENGINEERING INC

### Cantilevered Retaining Wall

#### Criteria

Retained Height	=	8.33 ft
Wall height above soil	=	0.00 ft
Slope Behind Wall	=	0.00
Height of Soil over Toe	=	0.00 in
Water height over heel	=	0.0 ft

#### Soil Data

Allow Soil Bearing	=	3,000.0 psf
Equivalent Fluid Pressure Method		
Active Heel Pressure	=	35.0 psf/ft
	=	
Passive Pressure	=	350.0 psf/ft
Soil Density, Heel	=	110.00 pcf
Soil Density, Toe	=	0.00 pcf
Footing  Soil Friction	=	0.350
Soil height to ignore for passive pressure	=	12.00 in

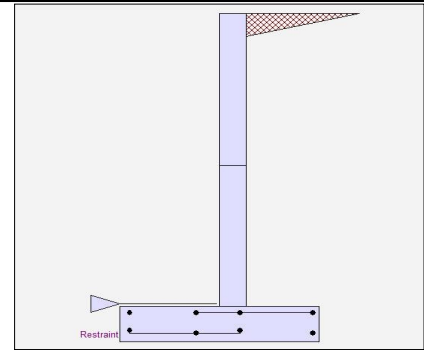

#### Surcharge Loads

Surcharge Over Heel	=	0.0 psf
Used To Resist Sliding & Overturning		
Surcharge Over Toe	=	0.0 psf
Used for Sliding & Overturning		

#### Lateral Load Applied to Stem

Lateral Load	=	0.0 #/ft
...Height to Top	=	0.00 ft
...Height to Bottom	=	0.00 ft
Load Type	=	Wind (W) (Service Level)
Wind on Exposed Stem	=	0.0 psf (Service Level)

#### Adjacent Footing Load

Adjacent Footing Load	=	0.0 lbs
Footing Width	=	0.00 ft
Eccentricity	=	0.00 in
Wall to Ftg CL Dist	=	0.00 ft
Footing Type	=	Line Load
Base Above/Below Soil at Back of Wall	=	0.0 ft
Poisson's Ratio	=	0.300

#### Axial Load Applied to Stem

Axial Dead Load	=	0.0 lbs
Axial Live Load	=	0.0 lbs
Axial Load Eccentricity	=	0.0 in

#### Earth Pressure Seismic Load

Method : Uniform		
Multiplier Used	=	7.000
(Multiplier used on soil density)		
Uniform Seismic Force	=	65.310
Total Seismic Force	=	609.342

#### Design Summary

##### Wall Stability Ratios

Overturning	=	1.65 OK
Slab Resists All Sliding !		
Total Bearing Load	=	3,263 lbs
...resultant ecc.	=	13.94 in
Soil Pressure @ Toe	=	1,625 psf OK
Soil Pressure @ Heel	=	0 psf OK
Allowable	=	3,000 psf
Soil Pressure Less Than Allowable		
ACI Factored @ Toe	=	2,275 psf
ACI Factored @ Heel	=	0 psf
Footing Shear @ Toe	=	27.9 psi OK
Footing Shear @ Heel	=	18.8 psi OK
Allowable	=	75.0 psi

##### Sliding Calcs

Lateral Sliding Force	=	1,949.9 lbs
-----------------------	---	-------------

#### Stem Construction

	2nd	Bottom
Design Height Above Ftg	ft = 4.00	Stem OK 0.00
Wall Material Above "Ht"	= Concrete	Concrete
Design Method	= LRFD	LRFD
Thickness	= 8.00	8.00
Rebar Size	= # 5	# 5
Rebar Spacing	= 16.00	8.00
Rebar Placed at	= Edge	Edge

##### Design Data

fb/FB + fa/Fa	=	0.219	0.638
---------------	---	-------	-------

##### Total Force @ Section

Service Level	lbs =		
Strength Level	lbs =	807.8	2,486.9

##### Moment....Actual

Service Level	ft-# =		
Strength Level	ft-# =	1,370.0	7,660.7

Moment....Allowable	ft-# =	6,234.5	11,990.5
---------------------	--------	---------	----------

##### Shear.....Actual

Service Level	psi =		
Strength Level	psi =	10.9	33.5

Shear.....Allowable	psi =	82.2	82.2
---------------------	-------	------	------

Anet (Masonry)	in2 =		
----------------	-------	--	--

Rebar Depth 'd'	in =	6.19	6.19
-----------------	------	------	------

##### Masonry Data

f'm	psi =		
Fs	psi =		
Solid Grouting	=		
Modular Ratio 'n'	=		

Wall Weight	psf =	100.0	100.0
-------------	-------	-------	-------

Short Term Factor	=		
-------------------	---	--	--

Equiv. Solid Thick.	=		
---------------------	---	--	--

Masonry Block Type	=	Medium Weight	
--------------------	---	---------------	--

Masonry Design Method	=	ASD	
-----------------------	---	-----	--

##### Concrete Data

f'c	psi =	3,000.0	3,000.0
-----	-------	---------	---------

Fy	psi =	60,000.0	60,000.0
----	-------	----------	----------

Vertical component of active lateral soil pressure IS NOT considered in the calculation of soil bearing

##### Load Factors

Building Code	IBC 2015,ACI
Dead Load	1.200
Live Load	1.600
Earth, H	1.600
Wind, W	1.000
Seismic, E	1.000

Walkout Cantilevered Wall

This Wall in File: P:\Client Files\203 - Architectural Innovations\2020\20001 - Pratt Plat

RetainPro (c) 1987-2019, Build 11.20.03.31  
License : KW-06059959  
License To : MULHERN & KULP STRUCTURAL ENGINEERING INC

**Cantilevered Retaining Wall**

**Concrete Stem Rebar Area Details**

2nd Stem	Vertical Reinforcing	Horizontal Reinforcing	
As (based on applied moment) :	0.0519 in2/ft		
(4/3) * As :	0.0692 in2/ft	Min Stem T&S Reinf Area 0.831 in2	
200bd/fy : 200(12)(6.1875)/60000 :	0.2475 in2/ft	Min Stem T&S Reinf Area per ft of stem Height : 0.192 in2/ft	
0.0018bh : 0.0018(12)(8) :	0.1728 in2/ft	Horizontal Reinforcing Options :	
	=====	One layer of :	Two layers of :
Required Area :	0.1728 in2/ft	#4@ 12.50 in	#4@ 25.00 in
Provided Area :	0.2325 in2/ft	#5@ 19.38 in	#5@ 38.75 in
Maximum Area :	1.0059 in2/ft	#6@ 27.50 in	#6@ 55.00 in

Bottom Stem	Vertical Reinforcing	Horizontal Reinforcing	
As (based on applied moment) :	0.2901 in2/ft		
(4/3) * As :	0.3868 in2/ft	Min Stem T&S Reinf Area 0.768 in2	
200bd/fy : 200(12)(6.1875)/60000 :	0.2475 in2/ft	Min Stem T&S Reinf Area per ft of stem Height : 0.192 in2/ft	
0.0018bh : 0.0018(12)(8) :	0.1728 in2/ft	Horizontal Reinforcing Options :	
	=====	One layer of :	Two layers of :
Required Area :	0.2901 in2/ft	#4@ 12.50 in	#4@ 25.00 in
Provided Area :	0.465 in2/ft	#5@ 19.38 in	#5@ 38.75 in
Maximum Area :	1.0059 in2/ft	#6@ 27.50 in	#6@ 55.00 in

**Footing Data**

Toe Width	=	2.50 ft
Heel Width	=	2.50
Total Footing Width	=	5.00
Footing Thickness	=	12.00 in
Key Width	=	0.00 in
Key Depth	=	0.00 in
Key Distance from Toe	=	0.00 ft
f'c =	2,500 psi	Fy = 60,000 psi
Footing Concrete Density	=	150.00 pcf
Min. As %	=	0.0018
Cover @ Top	2.00	@ Btm.= 3.00 in

**Footing Design Results**

		<u>Toe</u>	<u>Heel</u>
Factored Pressure	=	2,275	0 psf
Mu' : Upward	=	67,615	58 ft-#
Mu' : Downward	=	6,750	2,150 ft-#
Mu: Design	=	5,072	2,093 ft-#
Actual 1-Way Shear	=	27.89	18.79 psi
Allow 1-Way Shear	=	75.00	75.00 psi
Toe Reinforcing	=	# 5 @ 8.00 in	
Heel Reinforcing	=	# 4 @ 8.00 in	
Key Reinforcing	=	None Spec'd	
Footing Torsion, Tu	=		0.00 ft-lbs
Footing Allow. Torsion, phi Tu	=		0.00 ft-lbs

**If torsion exceeds allowable, provide supplemental design for footing torsion.**

**Other Acceptable Sizes & Spacings**

Toe: #4@ 9.25 in, #5@ 14.35 in, #6@ 20.37 in, #7@ 27.77 in, #8@ 36.57 in, #9@ 46  
Heel: #4@ 9.25 in, #5@ 14.35 in, #6@ 20.37 in, #7@ 27.77 in, #8@ 36.57 in, #9@ 46  
Key: No key defined

Min footing T&S reinf Area	1.30	in2
Min footing T&S reinf Area per foot	0.26	in2 /ft
If one layer of horizontal bars:	If two layers of horizontal bars:	
#4@ 9.26 in	#4@ 18.52 in	
#5@ 14.35 in	#5@ 28.70 in	
#6@ 20.37 in	#6@ 40.74 in	

This Wall in File: P:\Client Files\203 - Architectural Innovations\2020\20001 - Pratt Plat

RetainPro (c) 1987-2019, Build 11.20.03.31  
License : KW-06059959  
License To : MULHERN & KULP STRUCTURAL ENGINEERING INC

### Cantilevered Retaining Wall

#### Summary of Overturning & Resisting Forces & Moments

Item	.....OVERTURNING.....			.....RESISTING.....			
	Force lbs	Distance ft	Moment ft-#	Force lbs	Distance ft	Moment ft-#	
HL Act Pres (ab water tbl)	1,523.4	3.11	4,737.6	Soil Over HL (ab. water tbl)	1,679.9	4.08	6,859.5
HL Act Pres (be water tbl)				Soil Over HL (bel. water tbl)		4.08	6,859.5
Hydrostatic Force				Watre Table			
Buoyant Force =				Sloped Soil Over Heel =			
Surcharge over Heel =				Surcharge Over Heel =			
Surcharge Over Toe =				Adjacent Footing Load =			
Adjacent Footing Load =				Axial Dead Load on Stem =			
Added Lateral Load =				* Axial Live Load on Stem =			
Load @ Stem Above Soil =				Soil Over Toe =			
Seismic Earth Load =	426.5	4.67	1,989.8	Surcharge Over Toe =			
=				Stem Weight(s) =	833.0	2.83	2,360.2
<b>Total</b> =	<b>1,949.9</b>	<b>O.T.M. =</b>	<b>6,727.4</b>	Earth @ Stem Transitions =			
				Footing Weight =	750.0	2.50	1,875.0
				Key Weight =			
				Vert. Component =			
				<b>Total =</b>	<b>3,262.9 lbs</b>	<b>R.M.=</b>	<b>11,094.7</b>

**Resisting/Overturning Ratio**

= **1.65**  
Vertical Loads used for Soil Pressure = 3,262.9 lbs

\* Axial live load NOT included in total displayed, or used for overturning resistance, but is included for soil pressure calculation.

If seismic is included, the OTM and sliding ratios may be 1.1 per section 1807.2.3 of IBC.

Vertical component of active lateral soil pressure IS NOT considered in the calculation of Sliding Resistance.

Vertical component of active lateral soil pressure IS NOT considered in the calculation of Overturning Resistance.

#### Tilt

##### Horizontal Deflection at Top of Wall due to settlement of soil

(Deflection due to wall bending not considered)

Soil Spring Reaction Modulus 250.0 pci  
Horizontal Defl @ Top of Wall (approximate only) 0.075 in

The above calculation is not valid if the heel soil bearing pressure exceeds that of the toe, because the wall would then tend to rotate into the retained soil.

## Concrete Beam

Lic. # : KW-06004787

DESCRIPTION: Detail 17/SD-02 (Spanning side to side)

### Material Properties

$f'_c$	=	3.0 ksi	$\phi$ Phi Values	Flexure :	0.90
$f_r = f'_c^{1/2} * 7.50$	=	410.792 psi		Shear :	0.750
$\psi$ Density	=	145.0 pcf	$\beta_1$	=	0.850
$\lambda$ LtWt Factor	=	1.0			
Elastic Modulus	=	3,122.0 ksi	Fy - Stirrups	=	40.0 ksi
fy - Main Rebar	=	60.0 ksi	E - Stirrups	=	29,000.0 ksi
E - Main Rebar	=	29,000.0 ksi	Stirrup Bar Size #	=	3
			Number of Resisting Legs Per Stirrup =	=	2

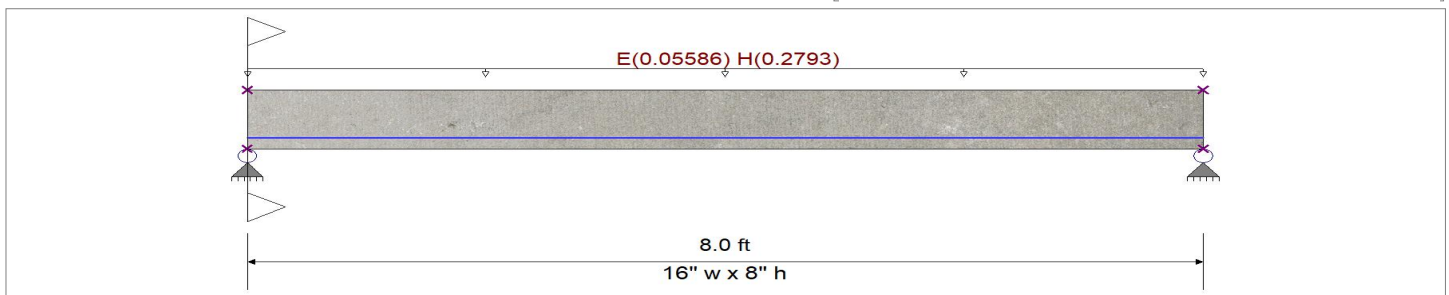
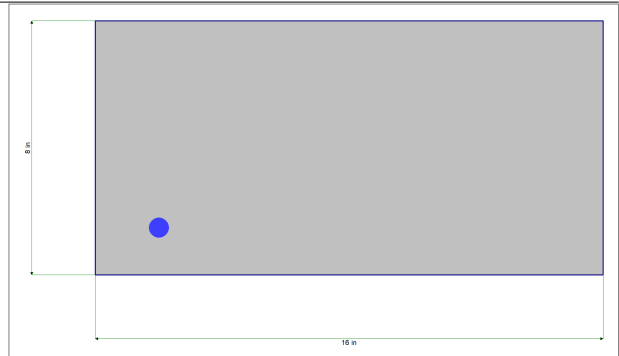

### Cross Section & Reinforcing Details

Rectangular Section, Width = 16.0 in, Height = 8.0 in

Span #1 Reinforcing....

1-#5 at 1.50 in from Bottom, from 0.0 to 8.0 ft in this span

Load for Span Number 1

Uniform Load : E = 0.0420, H = 0.210 ksf, Tributary Width = 1.330 ft

### DESIGN SUMMARY

**Design OK**

Maximum Bending Stress Ratio =	<b>0.460</b> : 1	Maximum Deflection	
Section used for this span	<b>Typical Section</b>	Max Downward Transient Deflection	0.012 in Ratio = 7951 >=360.
Mu : Applied	4.022 k-ft	Max Upward Transient Deflection	0.000 in Ratio = 0 <360.0
Mn * Phi : Allowable	8.750 k-ft	Max Downward Total Deflection	0.014 in Ratio = 6974 >=180.
Location of maximum on span	4.007 ft	Max Upward Total Deflection	0.000 in Ratio = 0 <180.0
Span # where maximum occurs	Span # 1		

### Vertical Reactions

Support notation : Far left is #1

Load Combination	Support 1	Support 2
Overall MAXimum	1.274	1.274
Overall MINimum	0.223	0.223
+D+H	1.117	1.117
+D+L+H	1.117	1.117
+D+Lr+H	1.117	1.117
+D+S+H	1.117	1.117
+D+0.750Lr+0.750L+H	1.117	1.117
+D+0.750L+0.750S+H	1.117	1.117
+D+0.60W+H	1.117	1.117
+D+0.750Lr+0.750L+0.450W+H	1.117	1.117
+D+0.750L+0.750S+0.450W+H	1.117	1.117
+0.60D+0.60W+0.60H	0.670	0.670
+D+0.70E+0.60H	0.827	0.827
+D+0.750L+0.750S+0.5250E+H	1.235	1.235

Project Title:  
 Engineer:  
 Project ID:  
 Project Descr:

## Concrete Beam

File: Foundation Wall Side to Side.ec6  
 Software copyright ENERCALC, INC. 1983-2020, Build:12.20.8.17  
 MULHERN & KULP STRUCTURAL ENGINEERING INC

Lic. #: KW-06004787

DESCRIPTION: Detail 17/SD-02 (Spanning side to side)

### Vertical Reactions

Support notation : Far left is #1

Load Combination	Support 1	Support 2
+0.60D+0.70E+H	1.274	1.274
E Only	0.223	0.223
H Only	1.117	1.117

### Detailed Shear Information

Load Combination	Span Number	Distance (ft)	'd' (in)	Vu (k)		Mu (k-ft)	d*Vu/Mu	Phi*Vc (k)	Comment	Phi*Vs (k)	Phi*Vn (k)	Spacing (in)	
				Actual	Design							Req'd	Suggest
+1.20D+L+0.20S+E+1.60H	1	0.00	6.50	2.01	2.01	0.00	1.00	8.70	Vu < PhiVc/2	lot Req'd 11.4	8.7	0.0	0.0
+1.20D+L+0.20S+E+1.60H	1	0.09	6.50	1.97	1.97	0.17	1.00	8.70	Vu < PhiVc/2	lot Req'd 11.4	8.7	0.0	0.0
+1.20D+L+0.20S+E+1.60H	1	0.17	6.50	1.92	1.92	0.34	1.00	8.70	Vu < PhiVc/2	lot Req'd 11.4	8.7	0.0	0.0
+1.20D+L+0.20S+E+1.60H	1	0.26	6.50	1.88	1.88	0.51	1.00	8.70	Vu < PhiVc/2	lot Req'd 11.4	8.7	0.0	0.0
+1.20D+L+0.20S+E+1.60H	1	0.35	6.50	1.84	1.84	0.67	1.00	8.70	Vu < PhiVc/2	lot Req'd 11.4	8.7	0.0	0.0
+1.20D+L+0.20S+E+1.60H	1	0.44	6.50	1.79	1.79	0.83	1.00	8.70	Vu < PhiVc/2	lot Req'd 11.4	8.7	0.0	0.0
+1.20D+L+0.20S+E+1.60H	1	0.52	6.50	1.75	1.75	0.99	0.96	8.68	Vu < PhiVc/2	lot Req'd 11.4	8.7	0.0	0.0
+1.20D+L+0.20S+E+1.60H	1	0.61	6.50	1.70	1.70	1.14	0.81	8.59	Vu < PhiVc/2	lot Req'd 11.4	8.6	0.0	0.0
+1.20D+L+0.20S+E+1.60H	1	0.70	6.50	1.66	1.66	1.28	0.70	8.52	Vu < PhiVc/2	lot Req'd 11.4	8.5	0.0	0.0
+1.20D+L+0.20S+E+1.60H	1	0.79	6.50	1.62	1.62	1.43	0.61	8.47	Vu < PhiVc/2	lot Req'd 11.4	8.5	0.0	0.0
+1.20D+L+0.20S+E+1.60H	1	0.87	6.50	1.57	1.57	1.57	0.54	8.43	Vu < PhiVc/2	lot Req'd 11.4	8.4	0.0	0.0
+1.20D+L+0.20S+E+1.60H	1	0.96	6.50	1.53	1.53	1.70	0.49	8.40	Vu < PhiVc/2	lot Req'd 11.4	8.4	0.0	0.0
+1.20D+L+0.20S+E+1.60H	1	1.05	6.50	1.48	1.48	1.83	0.44	8.37	Vu < PhiVc/2	lot Req'd 11.4	8.4	0.0	0.0
+1.20D+L+0.20S+E+1.60H	1	1.14	6.50	1.44	1.44	1.96	0.40	8.35	Vu < PhiVc/2	lot Req'd 11.4	8.3	0.0	0.0
+1.20D+L+0.20S+E+1.60H	1	1.22	6.50	1.40	1.40	2.08	0.36	8.33	Vu < PhiVc/2	lot Req'd 11.4	8.3	0.0	0.0
+1.20D+L+0.20S+E+1.60H	1	1.31	6.50	1.35	1.35	2.20	0.33	8.31	Vu < PhiVc/2	lot Req'd 11.4	8.3	0.0	0.0
+1.20D+L+0.20S+E+1.60H	1	1.40	6.50	1.31	1.31	2.32	0.31	8.29	Vu < PhiVc/2	lot Req'd 11.4	8.3	0.0	0.0
+1.20D+L+0.20S+E+1.60H	1	1.49	6.50	1.26	1.26	2.43	0.28	8.28	Vu < PhiVc/2	lot Req'd 11.4	8.3	0.0	0.0
+1.20D+L+0.20S+E+1.60H	1	1.57	6.50	1.22	1.22	2.54	0.26	8.27	Vu < PhiVc/2	lot Req'd 11.4	8.3	0.0	0.0
+1.20D+L+0.20S+E+1.60H	1	1.66	6.50	1.18	1.18	2.65	0.24	8.26	Vu < PhiVc/2	lot Req'd 11.4	8.3	0.0	0.0
+1.20D+L+0.20S+E+1.60H	1	1.75	6.50	1.13	1.13	2.75	0.22	8.25	Vu < PhiVc/2	lot Req'd 11.4	8.2	0.0	0.0
+1.20D+L+0.20S+E+1.60H	1	1.84	6.50	1.09	1.09	2.84	0.21	8.24	Vu < PhiVc/2	lot Req'd 11.4	8.2	0.0	0.0
+1.20D+L+0.20S+E+1.60H	1	1.92	6.50	1.04	1.04	2.94	0.19	8.23	Vu < PhiVc/2	lot Req'd 11.4	8.2	0.0	0.0
+1.20D+L+0.20S+E+1.60H	1	2.01	6.50	1.00	1.00	3.03	0.18	8.22	Vu < PhiVc/2	lot Req'd 11.4	8.2	0.0	0.0
+1.20D+L+0.20S+E+1.60H	1	2.10	6.50	0.96	0.96	3.11	0.17	8.21	Vu < PhiVc/2	lot Req'd 11.4	8.2	0.0	0.0
+1.20D+L+0.20S+E+1.60H	1	2.19	6.50	0.91	0.91	3.19	0.15	8.21	Vu < PhiVc/2	lot Req'd 11.4	8.2	0.0	0.0
+1.20D+L+0.20S+E+1.60H	1	2.27	6.50	0.87	0.87	3.27	0.14	8.20	Vu < PhiVc/2	lot Req'd 11.4	8.2	0.0	0.0
+1.20D+L+0.20S+E+1.60H	1	2.36	6.50	0.82	0.82	3.35	0.13	8.19	Vu < PhiVc/2	lot Req'd 11.4	8.2	0.0	0.0
+1.20D+L+0.20S+E+1.60H	1	2.45	6.50	0.78	0.78	3.42	0.12	8.19	Vu < PhiVc/2	lot Req'd 11.4	8.2	0.0	0.0
+1.20D+L+0.20S+E+1.60H	1	2.54	6.50	0.74	0.74	3.48	0.11	8.18	Vu < PhiVc/2	lot Req'd 11.4	8.2	0.0	0.0
+1.20D+L+0.20S+E+1.60H	1	2.62	6.50	0.69	0.69	3.55	0.11	8.18	Vu < PhiVc/2	lot Req'd 11.4	8.2	0.0	0.0
+1.20D+L+0.20S+E+1.60H	1	2.71	6.50	0.65	0.65	3.60	0.10	8.17	Vu < PhiVc/2	lot Req'd 11.4	8.2	0.0	0.0
+1.20D+L+0.20S+E+1.60H	1	2.80	6.50	0.60	0.60	3.66	0.09	8.17	Vu < PhiVc/2	lot Req'd 11.4	8.2	0.0	0.0
+1.20D+L+0.20S+E+1.60H	1	2.89	6.50	0.56	0.56	3.71	0.08	8.16	Vu < PhiVc/2	lot Req'd 11.4	8.2	0.0	0.0
+1.20D+L+0.20S+E+1.60H	1	2.97	6.50	0.52	0.52	3.76	0.07	8.16	Vu < PhiVc/2	lot Req'd 11.4	8.2	0.0	0.0
+1.20D+L+0.20S+E+1.60H	1	3.06	6.50	0.47	0.47	3.80	0.07	8.16	Vu < PhiVc/2	lot Req'd 11.4	8.2	0.0	0.0
+1.20D+L+0.20S+E+1.60H	1	3.15	6.50	0.43	0.43	3.84	0.06	8.15	Vu < PhiVc/2	lot Req'd 11.4	8.2	0.0	0.0
+1.20D+L+0.20S+E+1.60H	1	3.23	6.50	0.38	0.38	3.87	0.05	8.15	Vu < PhiVc/2	lot Req'd 11.4	8.1	0.0	0.0
+1.20D+L+0.20S+E+1.60H	1	3.32	6.50	0.34	0.34	3.91	0.05	8.14	Vu < PhiVc/2	lot Req'd 11.4	8.1	0.0	0.0
+1.20D+L+0.20S+E+1.60H	1	3.41	6.50	0.30	0.30	3.93	0.04	8.14	Vu < PhiVc/2	lot Req'd 11.4	8.1	0.0	0.0
+1.20D+L+0.20S+E+1.60H	1	3.50	6.50	0.25	0.25	3.96	0.03	8.14	Vu < PhiVc/2	lot Req'd 11.4	8.1	0.0	0.0
+1.20D+L+0.20S+E+1.60H	1	3.58	6.50	0.21	0.21	3.98	0.03	8.13	Vu < PhiVc/2	lot Req'd 11.4	8.1	0.0	0.0
+1.20D+L+0.20S+E+1.60H	1	3.67	6.50	0.16	0.16	3.99	0.02	8.13	Vu < PhiVc/2	lot Req'd 11.4	8.1	0.0	0.0
+1.20D+L+0.20S+E+1.60H	1	3.76	6.50	0.12	0.12	4.01	0.02	8.13	Vu < PhiVc/2	lot Req'd 11.4	8.1	0.0	0.0
+1.20D+L+0.20S+E+1.60H	1	3.85	6.50	0.08	0.08	4.02	0.01	8.12	Vu < PhiVc/2	lot Req'd 11.4	8.1	0.0	0.0
+1.20D+L+0.20S+E+1.60H	1	3.93	6.50	0.03	0.03	4.02	0.00	8.12	Vu < PhiVc/2	lot Req'd 11.4	8.1	0.0	0.0
+1.20D+L+0.20S+E+1.60H	1	4.02	6.50	-0.01	0.01	4.02	0.00	8.12	Vu < PhiVc/2	lot Req'd 11.4	8.1	0.0	0.0
+1.20D+L+0.20S+E+1.60H	1	4.11	6.50	-0.05	0.05	4.02	0.01	8.12	Vu < PhiVc/2	lot Req'd 11.4	8.1	0.0	0.0
+1.20D+L+0.20S+E+1.60H	1	4.20	6.50	-0.10	0.10	4.01	0.01	8.13	Vu < PhiVc/2	lot Req'd 11.4	8.1	0.0	0.0

Project Title:  
 Engineer:  
 Project ID:  
 Project Descr:

## Concrete Beam

Lic. #: KW-06004787

File: Foundation Wall Side to Side.ec6  
 Software copyright ENERCALC, INC. 1983-2020, Build:12.20.8.17  
**MULHERN & KULP STRUCTURAL ENGINEERING INC**

DESCRIPTION: Detail 17/SD-02 (Spanning side to side)

### Detailed Shear Information

Load Combination	Span Number	Distance (ft)	'd' (in)	Vu (k)		Mu (k-ft)	d*Vu/Mu	Phi*Vc (k)	Comment	Phi*Vs (k)	Phi*Vn (k)	Spacing (in)	
				Actual	Design							Req'd	Suggest
+1.20D+L+0.20S+E+1.60H	1	4.28	6.50	-0.14	0.14	4.00	0.02	8.13	Vu < PhiVc/2	lot Req'd 11.4	8.1	0.0	0.0
+1.20D+L+0.20S+E+1.60H	1	4.37	6.50	-0.19	0.19	3.99	0.03	8.13	Vu < PhiVc/2	lot Req'd 11.4	8.1	0.0	0.0
+1.20D+L+0.20S+E+1.60H	1	4.46	6.50	-0.23	0.23	3.97	0.03	8.14	Vu < PhiVc/2	lot Req'd 11.4	8.1	0.0	0.0
+1.20D+L+0.20S+E+1.60H	1	4.55	6.50	-0.27	0.27	3.95	0.04	8.14	Vu < PhiVc/2	lot Req'd 11.4	8.1	0.0	0.0
+1.20D+L+0.20S+E+1.60H	1	4.63	6.50	-0.32	0.32	3.92	0.04	8.14	Vu < PhiVc/2	lot Req'd 11.4	8.1	0.0	0.0
+1.20D+L+0.20S+E+1.60H	1	4.72	6.50	-0.36	0.36	3.89	0.05	8.15	Vu < PhiVc/2	lot Req'd 11.4	8.1	0.0	0.0
+1.20D+L+0.20S+E+1.60H	1	4.81	6.50	-0.41	0.41	3.86	0.06	8.15	Vu < PhiVc/2	lot Req'd 11.4	8.2	0.0	0.0
+1.20D+L+0.20S+E+1.60H	1	4.90	6.50	-0.45	0.45	3.82	0.06	8.15	Vu < PhiVc/2	lot Req'd 11.4	8.2	0.0	0.0
+1.20D+L+0.20S+E+1.60H	1	4.98	6.50	-0.49	0.49	3.78	0.07	8.16	Vu < PhiVc/2	lot Req'd 11.4	8.2	0.0	0.0
+1.20D+L+0.20S+E+1.60H	1	5.07	6.50	-0.54	0.54	3.73	0.08	8.16	Vu < PhiVc/2	lot Req'd 11.4	8.2	0.0	0.0
+1.20D+L+0.20S+E+1.60H	1	5.16	6.50	-0.58	0.58	3.68	0.09	8.17	Vu < PhiVc/2	lot Req'd 11.4	8.2	0.0	0.0
+1.20D+L+0.20S+E+1.60H	1	5.25	6.50	-0.63	0.63	3.63	0.09	8.17	Vu < PhiVc/2	lot Req'd 11.4	8.2	0.0	0.0
+1.20D+L+0.20S+E+1.60H	1	5.33	6.50	-0.67	0.67	3.58	0.10	8.18	Vu < PhiVc/2	lot Req'd 11.4	8.2	0.0	0.0
+1.20D+L+0.20S+E+1.60H	1	5.42	6.50	-0.71	0.71	3.51	0.11	8.18	Vu < PhiVc/2	lot Req'd 11.4	8.2	0.0	0.0
+1.20D+L+0.20S+E+1.60H	1	5.51	6.50	-0.76	0.76	3.45	0.12	8.19	Vu < PhiVc/2	lot Req'd 11.4	8.2	0.0	0.0
+1.20D+L+0.20S+E+1.60H	1	5.60	6.50	-0.80	0.80	3.38	0.13	8.19	Vu < PhiVc/2	lot Req'd 11.4	8.2	0.0	0.0
+1.20D+L+0.20S+E+1.60H	1	5.68	6.50	-0.85	0.85	3.31	0.14	8.20	Vu < PhiVc/2	lot Req'd 11.4	8.2	0.0	0.0
+1.20D+L+0.20S+E+1.60H	1	5.77	6.50	-0.89	0.89	3.23	0.15	8.20	Vu < PhiVc/2	lot Req'd 11.4	8.2	0.0	0.0
+1.20D+L+0.20S+E+1.60H	1	5.86	6.50	-0.93	0.93	3.15	0.16	8.21	Vu < PhiVc/2	lot Req'd 11.4	8.2	0.0	0.0
+1.20D+L+0.20S+E+1.60H	1	5.95	6.50	-0.98	0.98	3.07	0.17	8.22	Vu < PhiVc/2	lot Req'd 11.4	8.2	0.0	0.0
+1.20D+L+0.20S+E+1.60H	1	6.03	6.50	-1.02	1.02	2.98	0.19	8.23	Vu < PhiVc/2	lot Req'd 11.4	8.2	0.0	0.0
+1.20D+L+0.20S+E+1.60H	1	6.12	6.50	-1.07	1.07	2.89	0.20	8.23	Vu < PhiVc/2	lot Req'd 11.4	8.2	0.0	0.0
+1.20D+L+0.20S+E+1.60H	1	6.21	6.50	-1.11	1.11	2.80	0.21	8.24	Vu < PhiVc/2	lot Req'd 11.4	8.2	0.0	0.0
+1.20D+L+0.20S+E+1.60H	1	6.30	6.50	-1.15	1.15	2.70	0.23	8.25	Vu < PhiVc/2	lot Req'd 11.4	8.3	0.0	0.0
+1.20D+L+0.20S+E+1.60H	1	6.38	6.50	-1.20	1.20	2.60	0.25	8.26	Vu < PhiVc/2	lot Req'd 11.4	8.3	0.0	0.0
+1.20D+L+0.20S+E+1.60H	1	6.47	6.50	-1.24	1.24	2.49	0.27	8.27	Vu < PhiVc/2	lot Req'd 11.4	8.3	0.0	0.0
+1.20D+L+0.20S+E+1.60H	1	6.56	6.50	-1.29	1.29	2.38	0.29	8.29	Vu < PhiVc/2	lot Req'd 11.4	8.3	0.0	0.0
+1.20D+L+0.20S+E+1.60H	1	6.64	6.50	-1.33	1.33	2.26	0.32	8.30	Vu < PhiVc/2	lot Req'd 11.4	8.3	0.0	0.0
+1.20D+L+0.20S+E+1.60H	1	6.73	6.50	-1.37	1.37	2.15	0.35	8.32	Vu < PhiVc/2	lot Req'd 11.4	8.3	0.0	0.0
+1.20D+L+0.20S+E+1.60H	1	6.82	6.50	-1.42	1.42	2.02	0.38	8.34	Vu < PhiVc/2	lot Req'd 11.4	8.3	0.0	0.0
+1.20D+L+0.20S+E+1.60H	1	6.91	6.50	-1.46	1.46	1.90	0.42	8.36	Vu < PhiVc/2	lot Req'd 11.4	8.4	0.0	0.0
+1.20D+L+0.20S+E+1.60H	1	6.99	6.50	-1.51	1.51	1.77	0.46	8.39	Vu < PhiVc/2	lot Req'd 11.4	8.4	0.0	0.0
+1.20D+L+0.20S+E+1.60H	1	7.08	6.50	-1.55	1.55	1.63	0.51	8.42	Vu < PhiVc/2	lot Req'd 11.4	8.4	0.0	0.0
+1.20D+L+0.20S+E+1.60H	1	7.17	6.50	-1.59	1.59	1.50	0.58	8.45	Vu < PhiVc/2	lot Req'd 11.4	8.5	0.0	0.0
+1.20D+L+0.20S+E+1.60H	1	7.26	6.50	-1.64	1.64	1.36	0.65	8.50	Vu < PhiVc/2	lot Req'd 11.4	8.5	0.0	0.0
+1.20D+L+0.20S+E+1.60H	1	7.34	6.50	-1.68	1.68	1.21	0.75	8.55	Vu < PhiVc/2	lot Req'd 11.4	8.6	0.0	0.0
+1.20D+L+0.20S+E+1.60H	1	7.43	6.50	-1.73	1.73	1.06	0.88	8.63	Vu < PhiVc/2	lot Req'd 11.4	8.6	0.0	0.0
+1.20D+L+0.20S+E+1.60H	1	7.52	6.50	-1.77	1.77	0.91	1.00	8.70	Vu < PhiVc/2	lot Req'd 11.4	8.7	0.0	0.0
+1.20D+L+0.20S+E+1.60H	1	7.61	6.50	-1.81	1.81	0.75	1.00	8.70	Vu < PhiVc/2	lot Req'd 11.4	8.7	0.0	0.0
+1.20D+L+0.20S+E+1.60H	1	7.69	6.50	-1.86	1.86	0.59	1.00	8.70	Vu < PhiVc/2	lot Req'd 11.4	8.7	0.0	0.0
+1.20D+L+0.20S+E+1.60H	1	7.78	6.50	-1.90	1.90	0.43	1.00	8.70	Vu < PhiVc/2	lot Req'd 11.4	8.7	0.0	0.0
+1.20D+L+0.20S+E+1.60H	1	7.87	6.50	-1.95	1.95	0.26	1.00	8.70	Vu < PhiVc/2	lot Req'd 11.4	8.7	0.0	0.0
+1.20D+L+0.20S+E+1.60H	1	7.96	6.50	-1.99	1.99	0.09	1.00	8.70	Vu < PhiVc/2	lot Req'd 11.4	8.7	0.0	0.0

### Maximum Forces & Stresses for Load Combinations

Load Combination Segment	Span #	Location (ft) along Beam	Bending Stress Results (k-ft)		
			Mu : Max	Phi*Mnx	Stress Ratio
MAXimum BENDING Envelope					
Span # 1	1	8.000	4.02	8.75	0.46
+1.40D+1.60H	1	8.000	3.58	8.75	0.41
+1.20D+0.50Lr+1.60L+1.60H	1	8.000	3.58	8.75	0.41
+1.20D+1.60L+0.50S+1.60H	1	8.000	3.58	8.75	0.41
+1.20D+1.60Lr+L+1.60H	1	8.000	3.58	8.75	0.41

Project Title:  
 Engineer:  
 Project ID:  
 Project Descr:

**Concrete Beam**

File: Foundation Wall Side to Side.ec6  
 Software copyright ENERCALC, INC. 1983-2020, Build:12.20.8.17  
**MULHERN & KULP STRUCTURAL ENGINEERING INC**

Lic. # : KW-06004787

DESCRIPTION: Detail 17/SD-02 (Spanning side to side)

Load Combination Segment	Span #	Location (ft) along Beam	Bending Stress Results (k-ft)		
			Mu : Max	Phi*Mnx	Stress Ratio
+1.20D+1.60Lr+0.50W+1.60H Span # 1	1	8.000	3.58	8.75	0.41
+1.20D+L+1.60S+1.60H Span # 1	1	8.000	3.58	8.75	0.41
+1.20D+1.60S+0.50W+1.60H Span # 1	1	8.000	3.58	8.75	0.41
+1.20D+0.50Lr+L+W+1.60H Span # 1	1	8.000	3.58	8.75	0.41
+1.20D+L+0.50S+W+1.60H Span # 1	1	8.000	3.58	8.75	0.41
+0.90D+W+1.60H Span # 1	1	8.000	3.58	8.75	0.41
+1.20D+L+0.20S+E+1.60H Span # 1	1	8.000	4.02	8.75	0.46
+0.90D+E+0.90H Span # 1	1	8.000	2.46	8.75	0.28

**Overall Maximum Deflections**

Load Combination	Span	Max. "-" Defl (in)	Location in Span (ft)	Load Combination	Max. "+" Defl (in)	Location in Span (ft)
+0.60D+0.70E+H	1	0.0138	4.000		0.0000	0.000